

CAS 80gr	20010027
CAS 80ro	20010028
CAS 80ws	20010029
CAS 80gr o. Logo	20010036



Sat Antennas

Features

- Reflector made of aluminium, powder coated
- Feed system support made of galvanised sheet steel, powder coated
- Mast clamp made of sheet steel, hot-dip galvanised
- Optimal electrical data in lowest mechanical dimensions due to offset-feed
- Available in graphite, white or red brown
- Items supplied: Reflector with pre-assembled mast and feed system support, user manual
- Patented tilt facility at the multi-feed adaptor plate, allows optimisation of the LNB positions for multi-feed reception
- The optimum performance of the satellite antennas is only given in conjunction with the original Kathrein LNBS.



Printing may differ

- Without additional components, two universal feed systems to receive the signals of satellites 3° or 4° (e.g. ASTRA 19.2°/23.5°) or 6° apart (e.g. ASTRA/EUTELSAT-HOTBIRD) can be mounted on the boom.

For other satellite spacings, the multifeed adapter plates ZAS 90 (Order no: 218684) and ZAS 1218 (Order no: 204500011) are available (see „Optional Accessories“ on page 1).

Intended Use

The CAS 80 parabolic antenna is **intended solely for the reception of satellite signals** and for **use only as a domestic antenna**.

DIN 4131 specifies that a domestic antenna has no more than 6 m free mast length and a fixed-end moment up to 1650 Nm.

It is unsuitable for mounting on structures that are liable to vibration.

Make absolutely sure that the values for the maximum load listed in the Technical Data (on the last page) are complied with. If this load is exceeded, parts could break away!

The CAS 80 parabolic antenna is designed for use with a feed system (LNB) for reception of the signals from one satellite position, or two feed systems for multi-feed applications for reception of the signals from two satellite positions with 3° – 4° or 6° satellite spacing.

When the additional ZAS 90 or ZAS 1218 multi-feed adapter plate is used, the parabolic antenna is also suitable for three feed systems. The feed systems and instructions for their installation are not included in the scope of supply of the parabolic antenna.



Do not use the parabolic antenna for purposes other than those listed in this manual! Any use other than that specified above will void the warranty or guarantee.

In particular, **never modify** any of its **components** or **fit any components other** than those expressly intended by the manufacturer for use with the antenna.

Breach of these rules may lead to the antenna no longer being sufficiently stable and safe!

Optional Accessories

- ZAS 90, order no. 218684 multi-feed adapter plate



Installation items 2 and 3 cannot be mounted at the same time.

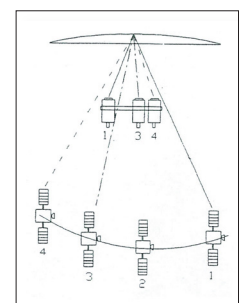
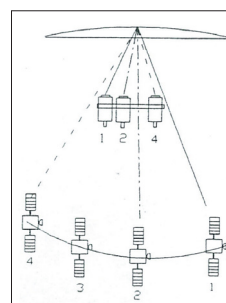

- ZAS 1218, order no. 204500011 multi-feed adapter plate
Without notches for any satellite spacing



Basic Safety Instructions

Before you install, connect or use the parabolic antenna, **make sure that you comply with the instructions in this manual!**

If you disregard these instructions,

- malfunctions may arise, creating **risks** to your life and health,
- defects in the installation or the connection may cause **damage** to the antenna or to the attachment point,
- the manufacturer will **not accept liability** for malfunctions and damage arising!



- Under no circumstances install antennas in the vicinity of overhead power cables, otherwise the absolutely essential clearance requirements may no longer be satisfied. Maintain a clearance of at least 1 m from all other electrical devices in all directions!

If you or metal parts of the antenna touch any electrical device there is a serious risk of a fatal electric shock!

- Never work on antenna systems during a thunderstorm or when a thunderstorm is approaching.
There is a risk of a fatal electric shock!
- Never install antennas on buildings with easily flammable roof coverings such as straw, reeds or similar materials!
Otherwise there is a risk of fire due to atmospheric over-voltages (static charges) or lightning discharges (e.g. during thunderstorms).
- The installation operations described here assume good craftsmanship capabilities and knowledge of the behaviour of materials under the effects of wind. Therefore if you do not possess the required skills, have this work performed by a specialist.
- The person doing the work must wear strong non-slip footwear, must not be liable to dizziness, must be able to move around safely on the roof and have a secure standing and attachment position (if necessary, wear a safety harness when on the roof).
- Make sure that the roof is able to bear your weight. Never walk on fragile or unstable surfaces! In case of doubt, contact a qualified specialist dealer or specialist roofing contractor to find an appropriate installation location.
- Do not go on to roofs or other high places without a correctly attached safety harness that is in good condition. Otherwise use a work platform.
- Ladders or other means of climbing must be in faultless condition (dry, clean and non-slip). Never build any irresponsible "scrambling towers"!
- If there is a risk that passers-by may be injured by items falling from above during installation, you must close off the risk area using barriers! Make sure that no-one is underneath the installation location.
Risk of death or injury due to falling from the roof, falling through the roof and falling parts, plus the possibility of damage to the roof.
- The respective national safety regulations and current standards such as DIN EN 60728-11 should be complied with.
- Any other use or failure to comply with these instructions will result in voiding of warranty coverage.



- Do not undo the cable tie on the carrier arm until you have swung out the boom and secured it using the two M6 bolts (see section "Installing the antenna" item c "Installing the carrier arm"). This is so as to prevent the boom swinging out during transport of the carrier arm. For this reason, always carry the carrier arm as show in the illustration on the right.
This is to avoid the risk of injury by pinching!



When working on antenna systems, please remember your **duty of care towards your fellow human beings!**

Keep the manual for any questions that arise later, and if the building passes to another owner, pass it on to the new owner!

Selecting the Installation Site

It is essential to select the correct installation site. This determines whether your parabolic antenna can be erected safely and perform to its optimum capabilities.

When selecting the installation site, take account of special features of the structure of the building. If the installation is at the edge of the roof or the building or on a cylindrical structure, DIN 1055, parts 4 and 4131 specifies the increased wind and vibration loadings that should be allowed for. The dynamic properties of the antenna and the structure can mutually influence each other and cause detrimental changes.

When installing (e.g. under eaves), due to the offset angle of the antenna, there must be a clear view to the satellite at an angle of approx. 60° above the top edge of the reflector in relation to the horizontal.

Disregarding these considerations can lead to the maximum load or vibration fatigue stress listed in the Technical Data being exceeded. **The parabolic antenna need not necessarily be mounted on the roof**, since the requirement is not height as such but an unobstructed "view" of the satellite. For this reason, an appropriate installation site might also be found for instance in the garden, on the terrace, on the face of the building or on a garage.

In fact if other sites are possible, it is better to avoid the roof. This will result in less work for you and will reduce the hazards associated with installation work on the roof!

- For good reception, an unobstructed "view" to the south ($\pm 20^\circ$) must be ensured, at an elevation of about 30° . The following satellites are then available for selection:

1 TÜRKSAT ^{*)}	42° East	6 EUTELSAT HOTBIRD	13° East
2 ASTRA 2 group ^{*)}	28.2° East	7 EUTELSAT W 1	10° East
3 ASTRA 3 group	23.5° East	8 HISPA-Sat	30° West
4 ASTRA 1 group	19.2° East		
5 EUTELSAT W 2	16° East		

- Do make sure that there are no obstacles between the parabolic antenna and the respective satellite (such as trees, roofs, house eaves or other antennas). Such items can impair reception to the extent that during unfavourable stormy weather the signal is lost altogether.

^{*)} The reception is dependent upon the respective location and the satellite coverage zone

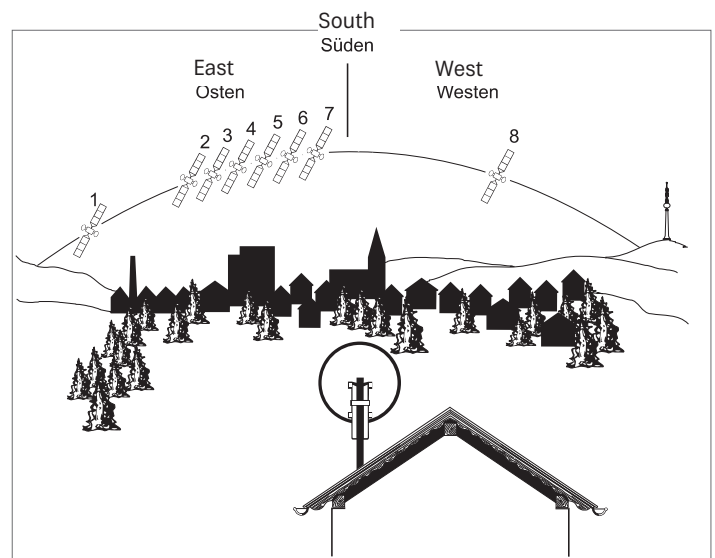

Installing the Antenna

When installing the antenna carrier (mast or wall boom), ensure that it is standing upright. Otherwise, there may be problems with the alignment of the antenna to the satellites.

a. Requirements on the antenna carrier

- Use only masts or support tubes that are specially designed for installation of antennas. Other tubes generally do not have the strength required to withstand the forces of wind and weather.
- For mast installation, select a tube diameter between 48 and 90 mm, with a wall thickness at least 2 mm. For wall installation, Kathrein recommends the use of ZAS 60 or ZAS 61 wall supports.
- For mast installation on a roof, the mast must be clamped for at least 1/6 of its free length (in the example bottom right this is 0.7 m).

b. Several antennas on a single antenna carrier

- Install the parabolic antenna as far down the mast as possible, so as to minimise the bending moment at the clamping point.
- Under no circumstances exceed the maximum value for the loading on the mast or mast support, as stated in the Technical Data. Sufficient cognizance of the maximum loading is achieved if you arrange your antenna system as shown in example bottom right and use conventional

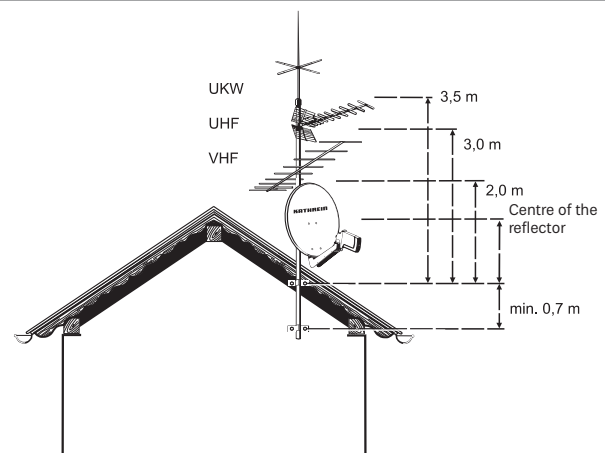
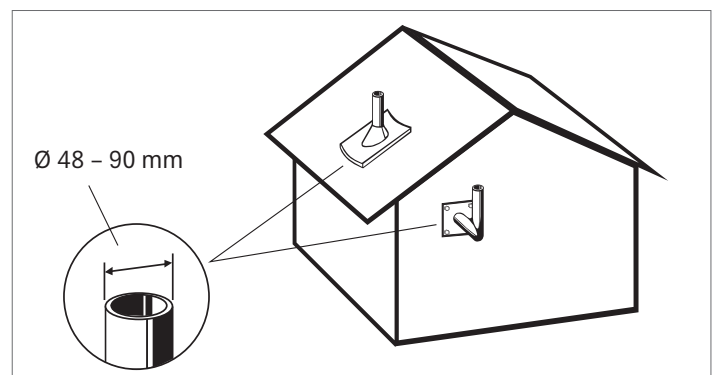

domestic antennas together with mast components from a specialist supplier (tube in steel grade St 52 with outside diameter 60 mm and wall thickness 2.5 mm at the mast clamping point – e.g. ZSH 59 from Kathrein).



If you arrange the structure differently you must calculate wind loading and bending moment at the clamping point as specified in DIN EN 60728-11 (or have a specialist do the calculation for you).

c. Installing the carrier arm

- Slacken the four bolts on the elevation scale, using the hexagon key supplied with the parabolic antenna.
- Now set the elevation value to suit the satellite(s) to be received and your actual location (see LNB manual). If you have no data relating to your location, set an elevation value of approx. 35° for the carrier arm. The desired scale value must be in the centre of the notch.
- Then use the hexagon key to tighten any two of the four bolts finger-tight.

(The fine adjustment of the elevation will be performed later; see the section *Aligning the Antenna* on p. 6.)

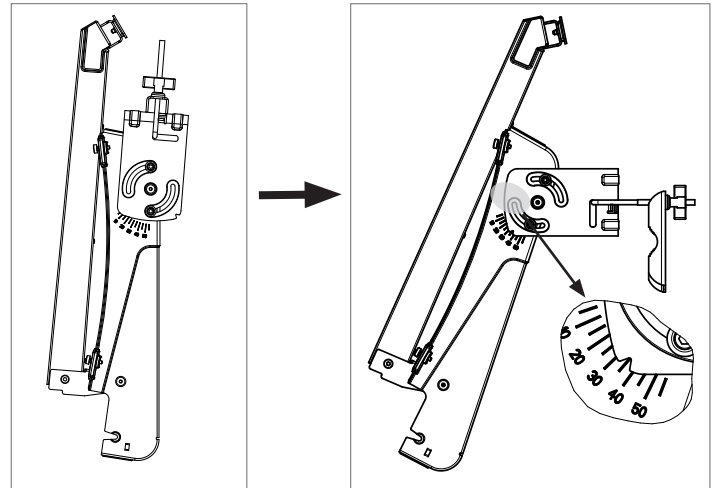

- Now secure the carrier arm to the mast tube/boom by tightening the wing nuts. Tighten the nuts initially only finger-tight and check that the alignment of the carrier arm is generally towards the south.

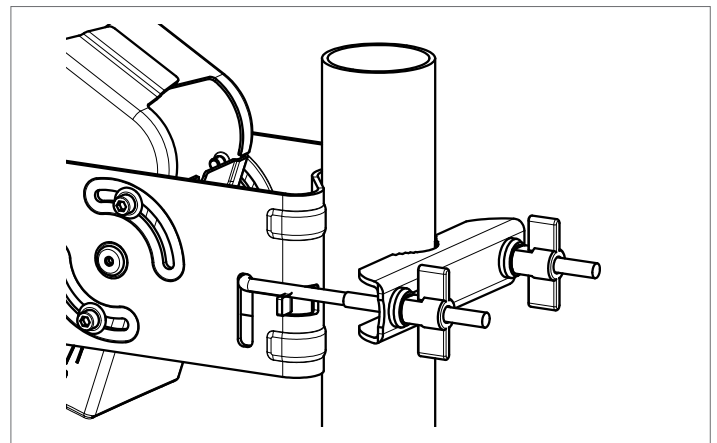

- Now hold the boom of the carrier arm firmly and remove the cable tie (see dashed circle in the diagram on the right).

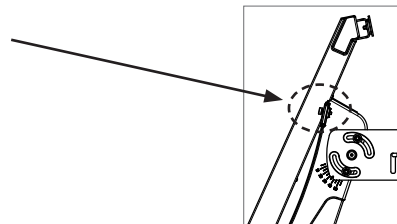

- Swing the carrier arm boom out and use the hexagon key to tighten the two M6 bolts at the "wrist" of the carrier arm to 4 – 5 Nm (see arrow in the diagram on the right).

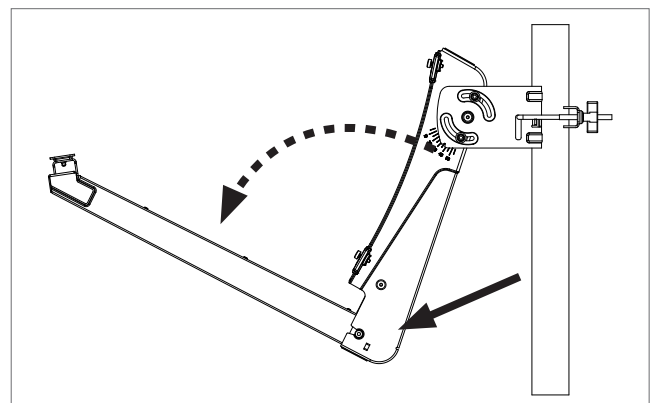

d. Installation of the parabolic antenna

- Now hang the parabolic reflector from the four securing bolts on the carrier arm (see arrows in the diagram on the right).
- Now lightly tighten the four bolts using a hexagon key SW5 (do this by holding the hexagon key by the short end, see diagram on the right).
- Now turn the hexagon key round. If you now swing the long end of the hexagon key (see diagram on the right) through about a quarter of a turn, the bolts will be tight. If you have a torque wrench available, tighten the bolts to about 4 – 5 Nm.

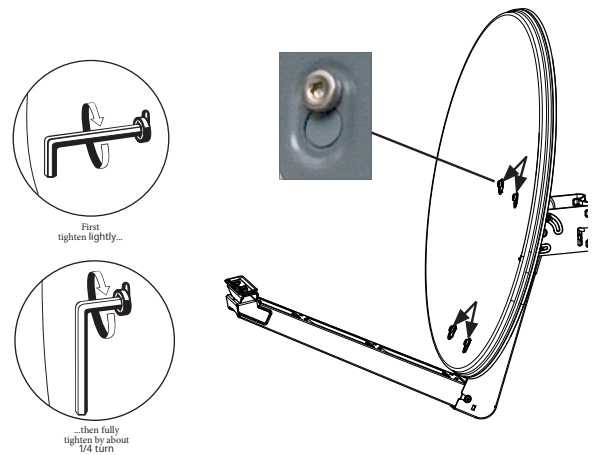

e. Feed system (LNB)

Tip For multi-feed applications the antenna should be aligned towards the satellite which is transmitting the weakest signal level.

Tip The optimum performance of the satellite antennas is only given in conjunction with the original Kathrein LNBS, because this is the only way to ensure optimum illumination of the reflector.

The feed system(s) and instructions for their installation are not included in the scope of supply of the parabolic antenna. For more detailed information on their correct installation please refer to the manuals supplied with the respective feed system.

Using the **multi-feed adaptor plate** on the carrier arm you can install one or two Kathrein universal feed systems. The markings on the adapter plate are as follows:

- 3 the installation position for one single feed system,
- 2 and 4 the installation positions for two multi-feed feed systems at 3° – 4° satellite spacing,
- 1 and 5 the installation positions for two multi-feed feed systems at 6° satellite spacing.

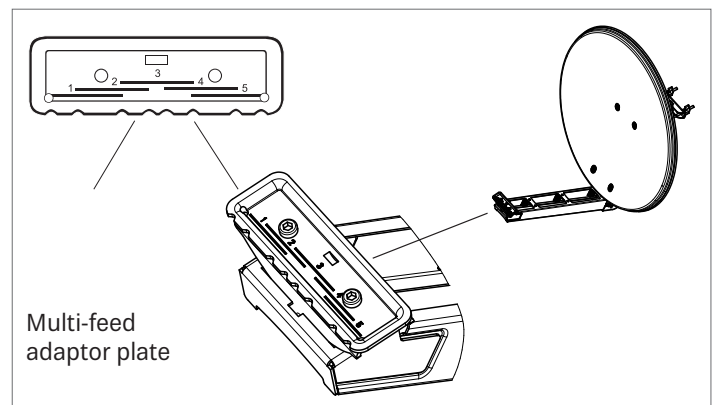

- Example for the installation positions for a multi-feed application with **3° – 4° satellite spacing**:

Position 2	Position 4
ASTRA 19.2° East	EUTELSAT 16° East
ASTRA 23.5° East	ASTRA 19.2° East
EUTELSAT 16° East	EUTELSAT 13° East
EUTELSAT 13° East	EUTELSAT 10° East
EUTELSAT 10° East	EUTELSAT 7° East

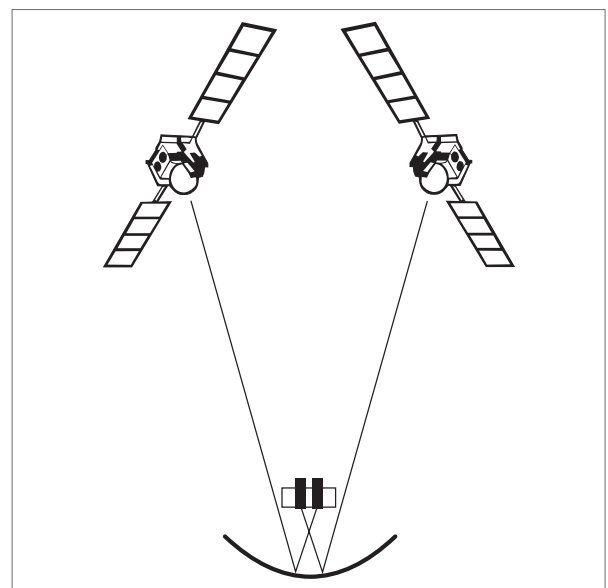

- Example for the installation positions for a multi-feed application with **6° satellite spacing**:

Position 1	Position 5
ASTRA 19.2° East	EUTELSAT 13° East
EUTELSAT 16° East	EUTELSAT 10° East
EUTELSAT 13° East	EUTELSAT 7° East

f. Polarisation pre-setting

• One feed system (monofeed)

Set the polarisation angle on the feed system according to the value in the table for your location and the position of the satellite from which the signal is to be received (see LNB user instructions). For this the tiltable adapter plate remains in the zero position (see diagram on the right).

• Multiple feed systems (multi-feed)

To optimise the multi-feed reception, the tiltable support "H" should be tilted to the angle "V" according to the table attached to this document.

The polarisation angle on the respective feed system must be set according to the following formula.

$$PW_{NEW} = PW_{TAB} - V$$

PW_{NEW} = polarisation angle to be set

PW_{TAB} = polarisation angle of the selected satellite according to the table in the LNB user instructions

V = setting angle of the support according to the selected satellite combination of the attached table

With the settings and the calculation, pay attention to preceding signs!

In order to be able to tilt the support you must first use the hexagon key to slacken the bolt shown arrowed in the illustration on the right.

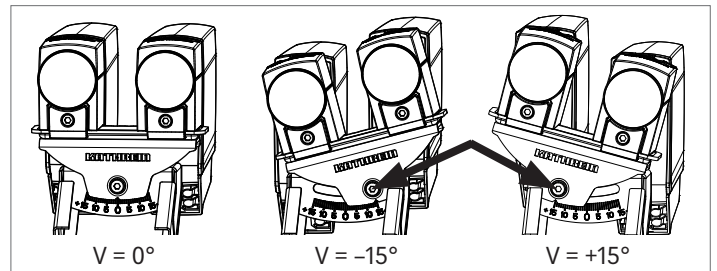
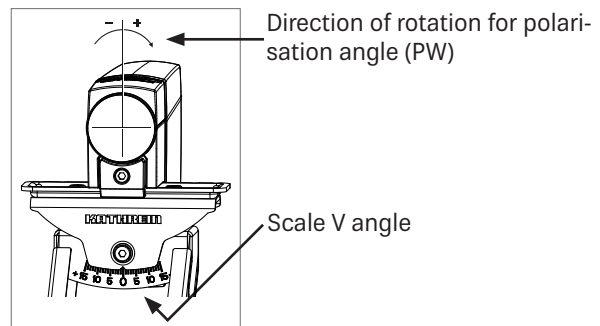
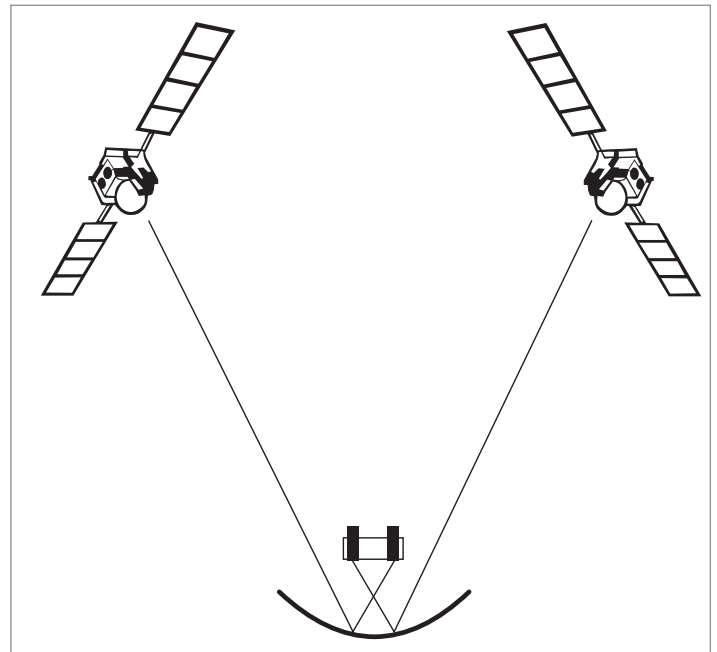

Aligning the Antenna

The antenna must be exactly aligned towards the satellite in respect of both the direction (azimuth) and also the inclination (elevation). For multi-feed applications the antenna should be aligned towards the satellite which is transmitting the weakest signal level.

a. Setting the inclination (elevation) (if not already set under "Installing the carrier arm")

- Use a hexagon key SW5 with the parabolic antenna to slacken the two screws on each side of the **inclination scale** (elevation) on the **left and right** of the support.
- Then adjust the **inclination** (elevation) - the exact elevation angle for your location can be found in the manual for the feed system (LNB).
- When doing this, retighten first just one of the bolts on the inclination scale finger-tight.

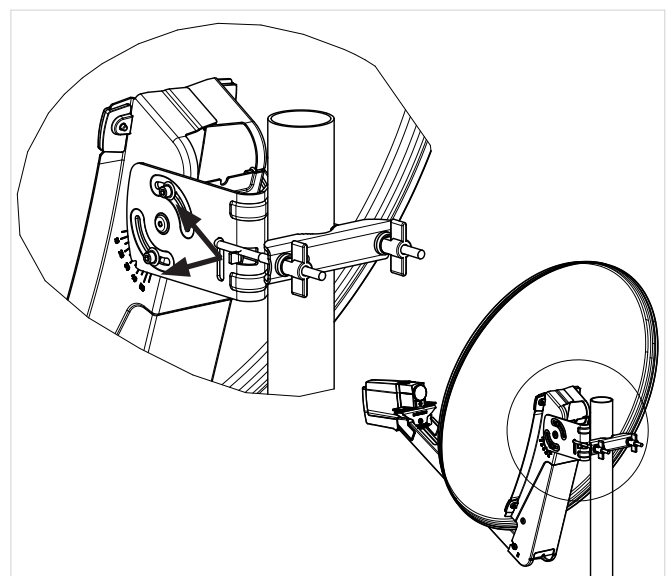

b. Setting the direction (azimuth)

If you yourself are unable whilst performing the adjustments to read the results of the alignment work on an **antenna meter** or **screen** connected to the satellite receiver, you may need an assistant for the following steps. The precise alignment of the antenna can be achieved only if a digital antenna meter is used. Ask your dealer about this.

- Set the satellite receiver to a known channel so that you can check that you have really "locked on" to the desired satellite.
- Now slightly loosen the wing nuts on the mast clamp.
- Twist the antenna so that it faces roughly south. Then slowly twist the antenna about its central axis to left and right until the best reception is obtained for the selected channel.
- Then tighten the **wing nuts** initially just enough to prevent the antenna turning.

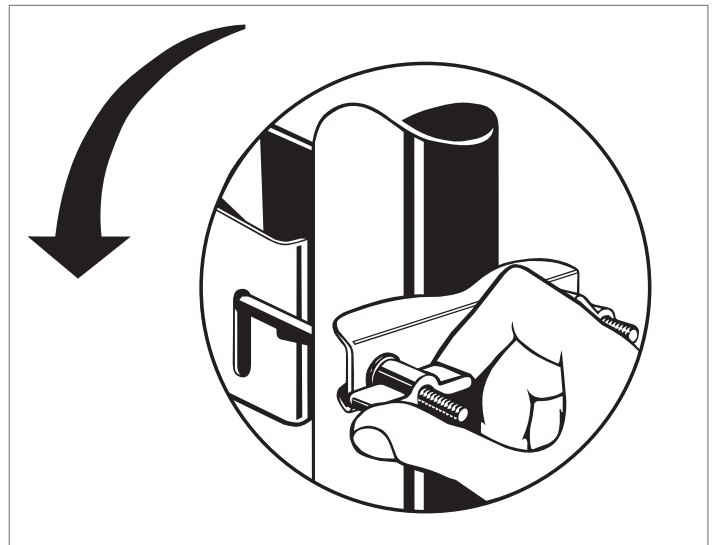

c. Fine adjustment

- Once again slacken the bolt on the inclination scale and tilt the antenna lightly upwards and downwards until either the antenna meter shows the strongest antenna signal or visual assessment is judged to achieve the best picture: To do this, tilt the antenna far enough upwards and downwards to get to the limits when the first "little fish" (analogue) or "little blocks" (digital) appear on the screen. Position the antenna midway between the two limit points.
- Now alternately correct the direction (azimuth) and inclination (elevation) until the measured results or the picture quality show no further improvement.

Note: *Tightening the nuts at the clamping piece can cause the antenna to turn slightly! You should allow for this at the fine adjustment stage (and if necessary make use of it when starting the adjustment operation all over again).*

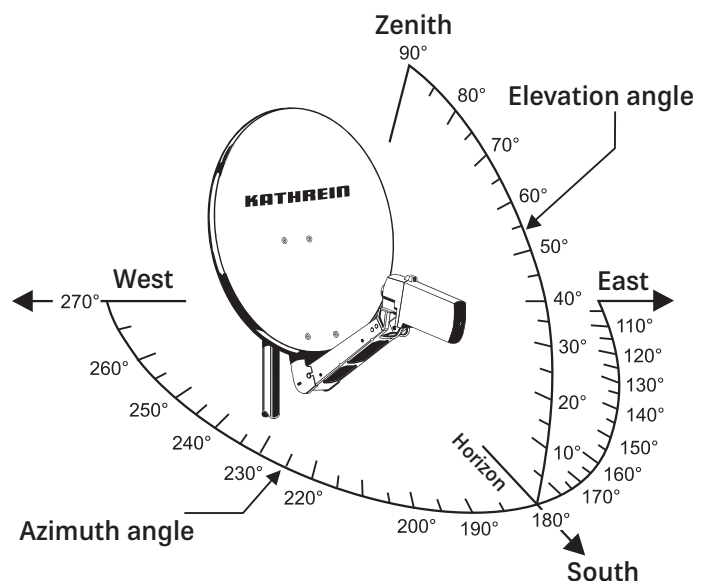

d. Finally tightening the antenna clamps

- Then tighten the nuts at the **clamping piece** by hand, working across diagonals. Then use a 13 AF open-ended spanner to tighten up each of the wing nuts one turn.
- After this, tighten the bolts on the **left and right** of the clamp of the **inclination scale**, using the hexagon key **first with the short end** to tighten them finger-tight and then with the **long end** tighten them a further **1/4 - 1/2 turn** (torque wrench: 4 - 5 Nm).
- **Finally check** once again that the bolted connections are secure.
- Attach the cables to the carrier arm by clipping them into the cable clips within the carrier arm and use **cable ties** to secure them all along the antenna carrier, so that they cannot chafe and suffer damage in the wind.

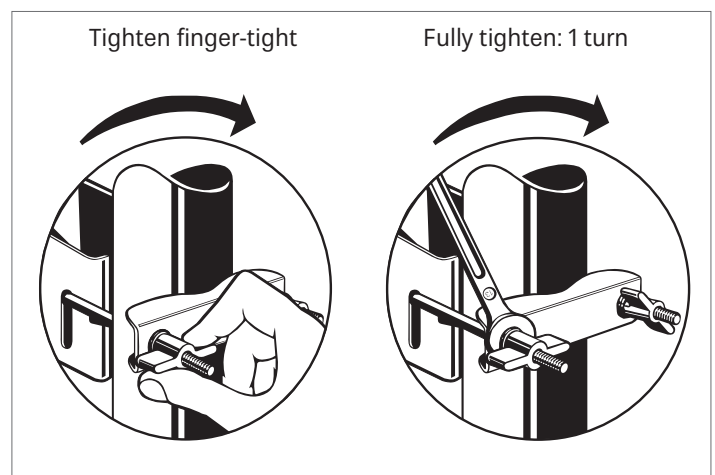

Antenna Grounding/Lightning Protection

Because of the serious consequences if the work is not done properly, grounding and lightning protection work may be performed only by specially trained electricians!



Never perform grounding and lightning protection work if you are not a specialist with the appropriate skills!

The instructions printed here are not an invitation to non-specialists to perform grounding and lightning protection work on their own account; they are meant solely as additional information for the specialists whom you employ!

The antenna must be erected to DIN EN 60728-11 and grounded as specified. The grounding requirement is inapplicable only to those antennas:

- more than 2 m below the edge of the roof
- and at the same time less than 1.5 m from buildings.

For grounding, the mast must be connected by means of a suitable ground conductor to the lightning protection system of the building, using the shortest route. If no lightning protection system is available: to the building's ground conductor.

Connection to the lightning protection system may be made only by a qualified lightning protection system installation engineer.

a. Suitable as ground conductors are

- a single solid wire with a cross-section of at least 16 mm² copper, at least 25 mm² aluminium or at least 50 mm² steel.

b. Unsuitable as ground conductors are

- the outer conductor of the antenna cable
- metallic domestic installations (such as the metal pipework of a water or heating system), since the permanence of the electrical connection cannot be guaranteed
- or the shielding conductor or neutral conductor of the mains power supply.

c. Routing of ground conductors

- Antenna cables and grounding conductors must not be routed through rooms used for storing easily flammable substances (such as hay or straw) or in which an explosive atmosphere can develop (such as gases, vapours).
- If the parabolic antenna is used in an integrated antenna system (e. g. a distribution system), the grounding measures must also be designed in such a way that grounding protection is still maintained if individual units are removed or replaced.

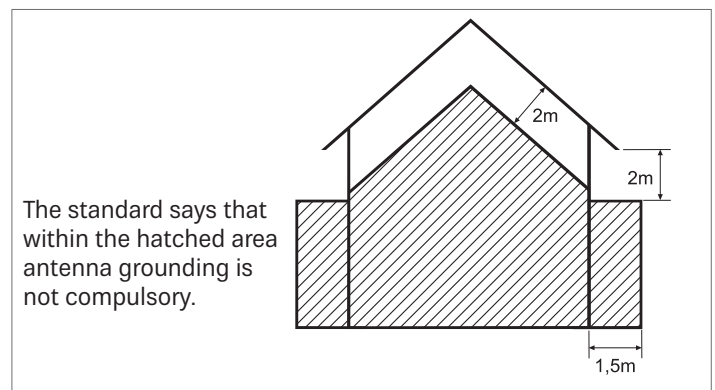
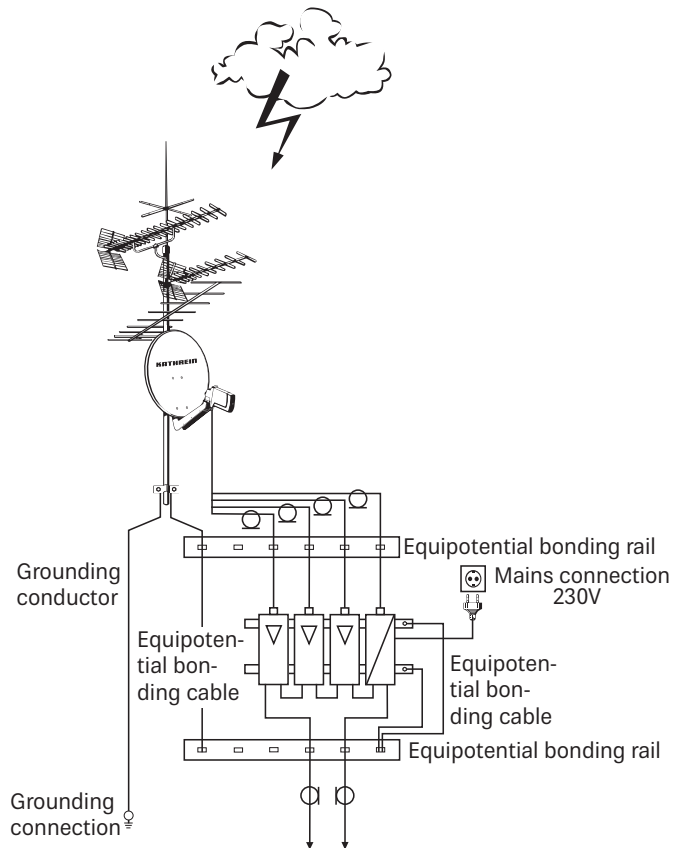

Hazards may be caused not only by thunderstorms (lightning), but also by static charges and short circuits in the connected units.

For safety reasons therefore in general for all antenna systems an equipotential bonding conductor of 4 mm² copper should be provided.

The cable screens of all coaxial antenna downlink cables must be connected to the mast with an equipotential bonding conductor.

Technical Data (typical values)

Type		CAS 80ws	CAS 80gr	CAS 80gr o. Logo	CAS 80ro
Order no.		20010029	20010027	20010036	20010028
Colour		White (RAL 9002)	Graphite (RAL 7012)	Graphite (RAL 7012)	Red brown (RAL 8012)
Reception range	GHz	10.70-12.75			
Antenna gain at 10.70-11.70 GHz/ 11.70-12.50 GHz/12.50-12.75 GHz	dBi	36.8/37.3/37.7			
Half-power beam width ¹⁾	°	< 2.2			
Figure of merit ²⁾ feed system in the middle;	UAS 571/572/582/584/585	dB/K	16.9/17.9		
			16.2/17.2		
Figure of merit ²⁾ feed system spacing 3° - 4°;	UAS 571/572/582/584/585	dB/K	16.6/17.4		
			15.8/16.8		
Figure of merit ²⁾ feed system spacing 6°;	UAS 571/572/582/584/585	dB/K	16.3/17.1		
			15.5/15.8		
Cross-polarisation decoupling (in main beam direction)	dB	> 26			
Wind area	m ²	0.47			
Vibration fatigue stress		ETS 300019-2-4 (12.94)/IEC Class 4 M 5			
Wind load 1:	N	450			
for installation height		up to 20 m above ground			
at wind speed	km/h	up to 130			
at dynamic pressure	N/m ²	800			
Wind load 2:	N	620			
for installation height		more than 20 m above ground (factor 1.37)			
at wind speed:	km/h	up to 150			
Maximum load	N	980			
at dynamic pressure	N/m ²	1740 (190 km/h)			
Mast clamp range	mm	38 - 90			
Setting range Elevation/Azimuth	°	Mast-side mounting: 5-48/360 Mast-top mounting: 5-90/360			
Multi-feed adaptor plate adjustment range (tiltable)	°	±15			
Packing unit dimensions	mm	1100 x 800 x 180			
Weight approx. net/gross	kg	6.7/8.0			

¹⁾ At mid-band

²⁾ G/T at 11.3/12.5 GHz under standard ambient conditions (clear sky)



If the maximum load is exceeded, parts could break away!

See dimensions on the next page

Dimensions in mm

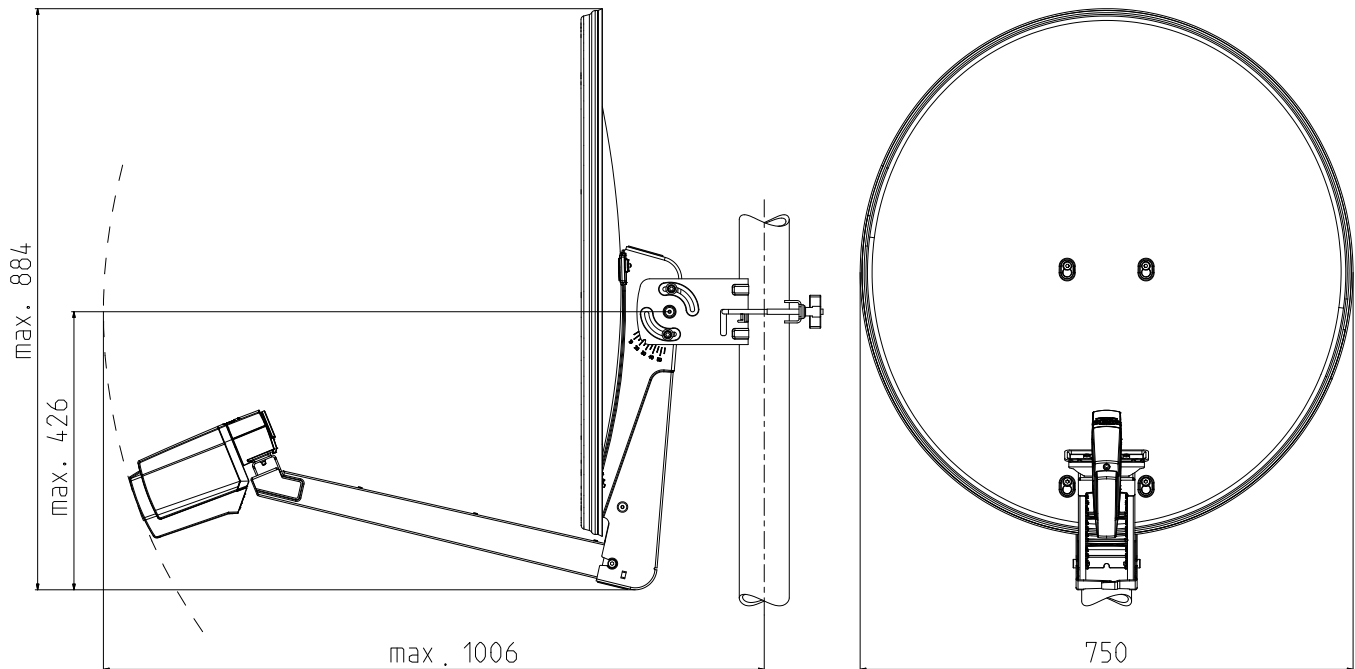

Warranty Conditions for the Antenna Corrosion Resistance

Important instructions relating to the warranty conditions for the corrosion resistance of Kathrein offset parabolic antennas:

- The antenna must be assembled and mounted professionally, following the steps described in the enclosed instruction sheet.
- The antenna must not be modified (e.g. by drilling).
- The antenna must not be damaged mechanically (e.g. deformation, deep or extensive damage, or abrasion of the powder coating and surface coating).
- The antenna must not be damaged due to exposure to chemicals (e.g. solvents, lacquers, detergents or the like).
- Only genuine Kathrein accessories may be used for the antenna.
- The consumer can make use of the warranty rights free of charge



These warranty conditions are effective from the date of purchase.

Only the original sales slip is acceptable as proof of purchase for warranty claims.

Furthermore, corrosion resistance is not warranted for the consequences of force majeure, e.g. lightning strike, or if the antenna is used in regions where frequently occurring, abrasive weather conditions may wear off the protective coating within a short period of time (e.g. sandstorms).

Service and support



All relevant information (address, telephone number, e-mail address, opening hours) for repairs or help with problems with our products can be found at:

<https://www.kathrein-ds.com/support/servicestellen>

Please note that there are different contact persons for **repair** and **support**!



Disposal



Electronic equipment

Electronic equipment is not domestic waste – in accordance with directive 2012/19/EU OF THE EUROPEAN PARLIAMENT AND THE COUNCIL dated 4th July 2012 concerning used electrical and electronic appliances, it must be disposed of properly. At the end of its service life, take this unit for disposal at a designated public collection point.

Table for Angle V of the Tiltable Multi-feed Adaptor Plate

Multi-feed Application 3° Orbital Spacing

Satellite		ASTRA/ Eutelsat W2 19,2°/16,0°	Eutelsat W2/Hotbird 16°/13°	Hotbird/ Eutelsat W2A 13°/10°	Eutelsat W2A/W3A 10°/7°	Atlantik Bird 3/2 -5,0°/-8,0°	ASTRA/ ASTRA 23,5°/19,2°	
■ Germany								
Bad Reichenhall	Latitude:	47,72°	-4,2°	-1,4°	1,3°	4,0°	16,5°	-7,5°
	Longitude	12,90°						
Berlin	Latitude:	52,50°	-3,2°	-0,8°	1,5°	3,7°	14,4°	-6°
	Longitude	13,42°						
Bremen	Latitude:	53,07°	-6,5°	-4,2°	-2,0°	0,2°	11,1°	-9,2°
	Longitude	8,83°						
Cottbus	Latitude:	51,75°	-2,6°	-0,1°	2,2°	4,5°	15,4°	-5,5°
	Longitude	14,33°						
Dortmund	Latitude:	51,50°	-7,9°	-5,5°	-3,2°	-0,8°	10,7°	-10,7°
	Longitude	7,47°						
Dresden	Latitude:	51,05°	-3,1°	-0,6°	1,8°	4,2°	15,3°	-6,1°
	Longitude	13,73°						
Emden	Latitude:	53,35°	-7,6°	-5,3°	-3,2°	-1,0°	9,9°	-10,2°
	Longitude	7,20°						
Erfurt	Latitude:	50,97°	-5,3°	-2,8°	-0,4°	2,0°	13,5°	-8,2°
	Longitude	11,03°						
Flensburg	Latitude:	54,78°	-5,7°	-3,5°	-1,4°	0,7°	10,8°	-8,2°
	Longitude	9,45°						
Frankfurt/Main	Latitude:	50,12°	-7,3°	-4,8°	-2,3°	0,1°	12,2°	-10,3°
	Longitude	8,68°						
Freiburg/Brsg.	Latitude:	48,00°	-8,6°	-5,9°	-3,3°	-0,6°	12,4°	-11,8°
	Longitude	7,83°						
Greifswald	Latitude:	54,08°	-3,0°	-0,8°	1,3°	3,5°	13,6°	-5,7°
	Longitude	13,38°						
Hamburg	Latitude:	53,55°	-5,5°	-3,3°	-1,1°	1,1°	11,7°	-8,2°
	Longitude	9,98°						
Hannover	Latitude:	52,37°	-5,9°	-3,6°	-1,3°	1,0°	12,0°	-8,7°
	Longitude	9,77°						
Kassel	Latitude:	51,30°	-6,4°	-4,0°	-1,6°	0,7°	12,2°	-9,3°
	Longitude	9,43°						
Kiel	Latitude:	54,32°	-5,3°	-3,1°	-1,0°	1,2°	11,5°	-7,9°
	Longitude	10,13°						
Koblenz	Latitude:	50,33°	-8,2°	-5,7°	-3,3°	-0,8°	11,2°	-11,1°
	Longitude	7,50°						
Leipzig	Latitude:	51,30°	-4,1°	-1,7°	0,7°	3,1°	14,3°	-7,1°
	Longitude	12,37°						
Magdeburg	Latitude:	52,12°	-4,6°	-2,2°	0,1°	2,4°	13,4°	-7,4°
	Longitude	11,63°						
Mönchengladbach	Latitude:	51,18°	-8,7°	-6,4°	-4,0°	-1,6°	10,1°	-11,6°
	Longitude	6,45°						
München	Latitude:	48,13°	-5,3°	-2,6°	0,1°	2,7°	15,3°	-8,6°
	Longitude	11,57°						
Neubrandenburg	Latitude:	53,55°	-3,2°	-0,9°	1,3°	3,5°	13,8°	-5,9°
	Longitude	13,25°						
Nürnberg	Latitude:	49,45°	-5,5°	-2,9°	-0,4°	2,2°	14,2°	-8,6°
	Longitude	11,05°						
Osnabrück	Latitude:	52,28°	-7,2°	-4,9°	-2,6°	-0,3°	10,9°	-10°
	Longitude	8,05°						

Satellite		ASTRA/ Eutelsat W2 19,2°/16,0°	Eutelsat W2/Hotbird 16°/13°	Hotbird/ Eutelsat W2A 13°/10°	Eutelsat W2A/W3A 10°/7°	Atlantik Bird 3/2 -5,0°/-8,0°	ASTRA/ ASTRA 23,5°/19,2°
■ Germany (continued)							
Passau	Latitude: 48,57°	-3,6°	-0,9°	1,7°	4,3°	16,5°	-6,8°
	Longitude 13,47°						
Pirmasens	Latitude: 49,20°	-8,4°	-5,9°	-3,3°	-0,8°	11,7°	-11,5°
	Longitude 7,60°						
Plauen	Latitude: 50,50°	-4,5°	-1,9°	0,5°	3,0°	14,5°	-7,5°
	Longitude 12,13°						
Ravensburg	Latitude: 47,77°	-7,1°	-4,4°	-1,7°	1,0°	13,9°	-10,4°
	Longitude 9,60°						
Regensburg	Latitude: 49,02°	-4,7°	-2,1°	0,5°	3,1°	15,2°	-7,9°
	Longitude 12,10°						
Rostock	Latitude: 54,08°	-3,9°	-1,7°	0,5°	2,6°	12,8°	-6,6°
	Longitude 12,13°						
Stuttgart	Latitude: 48,80°	-7,2°	-4,6°	-2,0°	0,6°	13,1°	-10,4°
	Longitude 9,18°						
Trier	Latitude: 49,75°	-9,1°	-6,5°	-4,1°	1,6°	10,8°	-12°
	Longitude 6,63°						
Ulm	Latitude: 48,38°	-6,7°	-4,0°	-1,3°	1,3°	13,9°	-9,9°
	Longitude 9,97°						
■ Austria							
Bregenz	Latitude: 47,50°	-7,1°	-4,3°	-1,6°	1,1°	14,2°	-10,4°
	Longitude 9,75°						
Graz	Latitude: 47,07°	-2,0°	0,9°	3,6°	6,4°	18,8°	-5,4°
	Longitude 15,45°						
Innsbruck	Latitude: 47,27°	-5,7°	-2,9°	-0,1°	2,6°	15,6°	-9°
	Longitude 11,38°						
Klagenfurt	Latitude: 46,63°	-3,1°	-0,2°	2,7°	5,4°	18,4°	-6,5°
	Longitude 14,33°						
Lienz	Latitude: 46,83°	-4,5°	-1,6°	1,2°	4,0°	16,9°	-7,9°
	Longitude 12,77°						
Linz	Latitude: 48,30°	-2,9°	-0,2°	2,5°	5,1°	17,2°	-6,2°
	Longitude 14,30°						
Salzburg	Latitude: 47,80°	-4,1°	-1,3°	1,4°	4,1°	16,6°	-7,4°
	Longitude 13,03°						
Wien	Latitude: 48,20°	-1,1°	1,7°	4,3°	6,9°	18,8°	-4,4°
	Longitude 16,37°						
■ Switzerland							
Bern	Latitude: 46,95°	-9,2°	-6,5°	-3,7°	-1,0°	12,5°	-10,8°
	Longitude 9,50°						
Genf	Latitude: 46,20°	-10,7°	-7,9°	-5,1°	-2,2°	11,7°	-14°
	Longitude 6,15°						
Locarno	Latitude: 46,17°	-8,3°	-5,4°	-2,6°	0,3°	14,0°	-11,7°
	Longitude 8,78°						
Zürich	Latitude: 47,37°	-8,2°	-5,4°	-2,7°	0,0°	13,2°	-11,5°
	Longitude 8,53°						

Satellite		ASTRA/ Eutelsat W2 19,2°/16,0°	Eutelsat W2/Hotbird 16°/13°	Hotbird/ Eutelsat W2A 13°/10°	Eutelsat W2A/W3A 10°/7°	Atlantik Bird 3/2 -5,0°/-8,0°	ASTRA/ ASTRA 23,5°/19,2°
-----------	--	--------------------------------------	-----------------------------------	-------------------------------------	-------------------------------	-------------------------------------	--------------------------------

■ Benelux Countries

Brügge (B)	Latitude: 51,22°	-11,1°	-8,8°	-6,5°	-4,2°	7,6°	-13,9°
	Longitude 3,22°						
Brüssel (B)	Latitude: 50,85°	-10,4°	-8,1°	-5,7°	-3,3°	8,6°	-13,3°
	Longitude 4,35°						
Den Haag (NL)	Latitude: 52,12°	-10,0°	-7,8°	-5,5°	-3,2°	8,2°	-12,8°
	Longitude 4,28°						
Eindhoven (NL)	Latitude: 51,43°	-9,4°	-7,1°	-4,7°	-2,4°	9,3°	-12,2°
	Longitude 5,47°						
Enschede (NL)	Latitude: 52,22°	-8,1°	-5,8°	-3,5°	-1,2°	10,0°	-10,9°
	Longitude 6,88°						
Groningen (NL)	Latitude: 53,25°	-8,0°	-5,8°	-3,6°	-1,4°	9,5°	-10,7°
	Longitude 6,58°						
Luxemburg (L)	Latitude: 49,62°	-9,5°	-7,0°	-4,5°	-2,0°	10,4°	-12,5°
	Longitude 6,15°						
Maastricht (NL)	Latitude: 50,83°	-9,4°	-7,1°	-4,7°	-2,3°	9,6°	-12,3°
	Longitude 5,67°						

■ France

Bastia	Latitude: 42,67°	-8,6°	-5,4°	-2,2°	1,1°	16,4°	-12,5°
	Longitude 9,50°						
Bayonne	Latitude: 43,50°	-18,6°	-15,9°	-13,1°	-10,2°	5,2°	-19,6°
	Longitude -1,47°						
Bordeaux	Latitude: 44,83°	-17,1°	-14,5°	-11,8°	-8,9°	5,9°	-20,5°
	Longitude -0,60°						
Brest	Latitude: 48,40°	-18,1°	-15,9°	-13,6°	-11,2°	1,7°	-21°
	Longitude -4,52°						
Calais	Latitude: 50,95°	-12,2°	-9,9°	-7,6°	-5,3°	6,7°	-15°
	Longitude 1,93°						
Clermont-Ferrand	Latitude: 45,77°	-13,5°	-10,8°	-8,0°	-5,2°	9,1°	-16,9°
	Longitude 3,07°						
Dijon	Latitude: 47,33°	-11,2°	-8,5°	-5,9°	-3,2°	10,3°	-14,4°
	Longitude 5,05°						
Le Havre	Latitude: 49,50°	-14,2°	-11,8°	-9,5°	-7,1°	5,5°	-17,1°
	Longitude 0,08°						
Limoges	Latitude: 45,83°	-15,1°	-12,4°	-9,7°	-6,9°	7,4°	-18,3°
	Longitude 1,25°						
Lyon	Latitude: 45,77°	-12,0°	-9,2°	-6,4°	-3,5°	10,7°	-15,4°
	Longitude 4,83°						
Marseille	Latitude: 43,30°	-12,5°	-9,5°	-6,4°	-3,3°	12,2°	-16,2°
	Longitude 5,38°						
Metz	Latitude: 49,13°	-9,6°	-7,1°	-4,6°	-2,0°	10,6°	-12,7°
	Longitude 6,17°						
Nantes	Latitude: 47,20°	-16,6°	-14,1°	-11,7°	-9,1°	4,5°	-19,7°
	Longitude -1,55°						

Satellite		ASTRA/ Eutelsat W2 19,2°/16,0°	Eutelsat W2/Hotbird 16°/13°	Hotbird/ Eutelsat W2A 13°/10°	Eutelsat W2A/W3A 10°/7°	Atlantik Bird 3/2 -5,0°/-8,0°	ASTRA/ ASTRA 23,5°/19,2°
-----------	--	--------------------------------------	-----------------------------------	-------------------------------------	-------------------------------	-------------------------------------	--------------------------------

■ France (continued)

Nizza	Latitude: 43,70°	-10,6°	-7,5°	-4,4°	-1,3°	13,8°	-14,2°
	Longitude 7,23°						
Orleans	Latitude: 47,90°	-13,6°	-11,0°	-8,5°	-5,9°	7,4°	-16,7°
	Longitude 1,87°						
Paris	Latitude: 48,83°	-12,8°	-10,3°	-7,9°	-5,3°	7,6°	-15,8°
	Longitude 2,33°						
Reims	Latitude: 49,25°	-11,3°	-8,8°	-6,3°	-3,8°	8,8°	-14,3°
	Longitude 4,02°						
Rennes	Latitude: 48,12°	-16,2°	-13,8°	-11,4°	-8,9°	4,3°	-19,2°
	Longitude -1,68°						
Toulouse	Latitude: 43,62°	-16,0°	-13,2°	-10,3°	-7,3°	8,2°	-19,5°
	Longitude 1,45°						
Tours	Latitude: 47,37°	-14,8°	-12,2°	-9,7°	-7,1°	6,5°	-17,9°
	Longitude 0,67°						

■ Unigted Kingdom of Great Britain and Northern Ireland

Aberdeen	Latitude: 57,15°	-12,1°	-10,3°	-8,5°	-6,7°	2,8°	-14,3°
	Longitude -2,10°						
Belfast	Latitude: 54,58°	-15,6°	-13,7°	-11,9°	-9,9°	0,4°	-17,9°
	Longitude -5,93°						
Birmingham	Latitude: 52,50°	-14,1°	-12,1°	-10,0°	-7,8°	3,5°	-16,7°
	Longitude -1,92°						
Bristol	Latitude: 51,43°	-15,1°	-13,0°	-10,8°	-8,6°	3,1°	-17,8°
	Longitude -2,58°						
Glasgow	Latitude: 55,87°	-13,9°	-12,1°	-10,3°	-8,4°	1,5°	-16,2°
	Longitude -4,23°						
London	Latitude: 51,50°	-13,4°	-11,2°	-9,0°	-6,7°	5,0°	-16,1°
	Longitude -0,08°						
Manchester	Latitude: 53,50°	-13,9°	-11,9°	-9,9°	-7,8°	3,1°	-16,4°
	Longitude -2,25°						
Newcastle	Latitude: 54,22°	-15,7°	-13,9°	-12,0°	-10,0°	0,4°	-18,1°
	Longitude -5,90°						
Norwich	Latitude: 52,63°	-11,9°	-9,8°	-7,6°	-5,4°	5,8°	-14,6°
	Longitude 1,28°						
Plymouth	Latitude: 50,38°	-16,7°	-14,6°	-12,4°	-	1,9°	-19,5°
	Longitude -4,15°						

■ Italy

Ancona	Latitude: 43,62°	-4,3°	-1,0°	2,1°	5,2°	19,3°	-8,1°
	Longitude 13,50°						
Bari	Latitude: 41,10°	-0,8°	2,7°	6,1°	9,4°	23,7°	-5,1°
	Longitude 16,87°						
Bologna	Latitude: 44,50°	-6,3°	-3,2°	-0,2°	2,9°	17,0°	-10°
	Longitude 11,33°						
Bozen	Latitude: 46,50°	-5,9°	-3,0°	-0,2°	2,7°	15,9°	-9,3°
	Longitude 11,33°						

Satellite		ASTRA/ Eutelsat W2 19,2°/16,0°	Eutelsat W2/Hotbird 16°/13°	Hotbird/ Eutelsat W2A 13°/10°	Eutelsat W2A/W3A 10°/7°	Atlantik Bird 3/2 -5,0°/-8,0°	ASTRA/ ASTRA 23,5°/19,2°
-----------	--	--------------------------------------	-----------------------------------	-------------------------------------	-------------------------------	-------------------------------------	--------------------------------

■ Italy (continued)

Cagliari	Latitude: 39,25°	-10,2°	-6,5°	-2,9°	0,7°	17,9°	-14,5°
	Longitude 9,10°						
Catania	Latitude: 37,52°	-3,3°	0,7°	4,6°	8,4°	24,8°	-8,1°
	Longitude 15,07°						
Cosenza	Latitude: 39,28°	-1,7°	2,1°	5,7°	9,3°	24,5°	-6,2°
	Longitude 16,23°						
Florenz	Latitude: 43,78°	-6,5°	-3,4°	-0,3°	2,8°	17,3°	-10,3°
	Longitude 11,25°						
Foggia	Latitude: 41,47°	-2,3°	1,1°	4,5°	7,8°	22,4°	-6,5°
	Longitude 15,52°						
Genua	Latitude: 44,40°	-8,7°	-5,6°	-2,6°	0,4°	15,0°	-12,3°
	Longitude 8,93°						
Mailand	Latitude: 45,47°	-8,1°	-5,2°	-2,3°	0,7°	14,7°	-11,6°
	Longitude 9,17°						
Neapel	Latitude: 40,83°	-3,8°	-0,3°	3,2°	6,6°	21,8°	-8,1°
	Longitude 14,28°						
Palermo	Latitude: 38,13°	-5,4°	-1,5°	2,3°	6,1°	22,8°	-10°
	Longitude 13,33°						
Pescara	Latitude: 42,47°	-3,7°	-0,3°	2,9°	6,2°	20,6°	-7,7°
	Longitude 14,22°						
Rimini	Latitude: 44,05°	-5,2°	-2,0°	1,1°	4,1°	18,3°	-8,9°
	Longitude 12,55°						
Rom	Latitude: 41,90°	-5,6°	-2,2°	1,1°	4,4°	19,5°	-9,7°
	Longitude 12,50°						
Sassari	Latitude: 40,73°	-10,2°	-6,8°	-3,4°	0,1°	16,5°	-14,3°
	Longitude 8,55°						
Taranto	Latitude: 40,50°	-0,5°	3,1°	6,6°	9,9°	24,4°	-4,8°
	Longitude 17,18°						
Turin	Latitude: 45,07°	-9,7°	-6,7°	-3,8°	-0,8°	13,5°	-13,2°
	Longitude 7,67°						
Trieste	Latitude: 45,65°	-3,7°	-0,7°	2,2°	5,1°	18,3°	-7,3°
	Longitude 13,75°						
Venedig	Latitude: 45,45°	-5,1°	-2,1°	0,8°	3,7°	17,3°	-8,7°
	Longitude 12,33°						
Verona	Latitude: 45,45°	-6,4°	-3,4°	-0,5°	2,4°	16,2°	-10°
	Longitude 11,00°						

■ Spain

Albacete	Latitude: 39,00°	-21,8°	-18,8°	-15,6°	-12,3°	5,7°	-25,3°
	Longitude -1,83°						
Algeciras	Latitude: 36,15°	-27,2°	-24,3°	-21,3°	-18,0°	1,4°	-31,5°
	Longitude -5,47°						
Alicante	Latitude: 38,38°	-20,9°	-17,8°	-14,5°	-11,1°	7,5°	-25°
	Longitude -0,50°						

Satellite		ASTRA/ Eutelsat W2 19,2°/16,0°	Eutelsat W2/Hotbird 16°/13°	Hotbird/ Eutelsat W2A 13°/10°	Eutelsat W2A/W3A 10°/7°	Atlantik Bird 3/2 -5,0°/-8,0°	ASTRA/ ASTRA 23,5°/19,2°
■ Spain (continued)							
Almeria	Latitude: 36,87°	-23,9°	-20,8°	-17,5°	-14,0°	5,3°	-28,1°
	Longitude -2,45°						
Avila	Latitude: 40,65°	-23,2°	-20,5°	-17,7°	-14,7°	2,1°	-26,9°
	Longitude -4,72°						
Badajoz	Latitude: 38,83°	-26,4°	-23,8°	-21,0°	-18,0°	-0,6°	-30,3°
	Longitude -6,98°						
Barcelona	Latitude: 41,35°	-16,5°	-13,5°	-10,3°	7,1°	9,6°	-29,3°
	Longitude 2,17°						
Burgos	Latitude: 42,35°	-21,2°	-18,5°	-15,8°	-12,9°	3,1°	-24,7°
	Longitude -3,68°						
Cadiz	Latitude: 36,50°	-27,7°	-24,9°	-21,9°	-18,7°	0,2°	-31,9°
	Longitude -6,33°						
Cartagena	Latitude: 37,63°	-21,9°	-18,7°	-15,4°	-11,9°	7,1°	-26,1°
	Longitude -0,98°						
Cordoba	Latitude: 37,83°	-25,3°	-22,5°	-19,5°	-16,3°	2,1°	-29,4°
	Longitude -4,83°						
Gijon	Latitude: 43,53°	-22,0°	-19,5°	-17,0°	-14,3°	0,8°	-25,4°
	Longitude -5,70°						
Granada	Latitude: 37,17°	-24,7°	-21,7°	-18,6°	-15,2°	3,8°	-28,9°
	Longitude -3,58°						
Ibiza	Latitude: 38,90°	-18,7°	-15,4°	-12,1°	-8,6°	9,6°	-22,7°
	Longitude 1,43°						
La Coruna	Latitude: 43,33°	-24,2°	-21,9°	-19,4°	-16,8°	-2,0°	-27,6°
	Longitude -8,42°						
Madrid	Latitude: 40,42°	-22,5°	-19,8°	-16,9°	-13,8°	3,2°	-26,3°
	Longitude -3,75°						
Malaga	Latitude: 36,72°	-25,8°	-22,8°	-19,7°	-16,4°	2,8°	-30°
	Longitude -4,38°						
Palma de Mallorca	Latitude: 39,58°	-17,0°	-13,8°	-10,4°	-7,0°	10,8°	-21,1°
	Longitude 2,65°						
Salamanca	Latitude: 40,97°	-23,7°	-21,1°	-18,4°	-15,5°	1,0°	-27,4°
	Longitude -5,65						
San Sebastian	Latitude: 43,28°	-19,2°	-16,5°	-13,7°	-10,8°	4,8°	-22,6°
	Longitude -1,97°						
Santa Cruz del Retamar	Latitude: 41,33°	-22,3°	-19,6°	-16,8°	-13,9°	2,6°	-26°
	Longitude -4,23°						
Santander	Latitude: 43,45°	-20,6°	-18,0°	-15,4°	-12,6°	2,8°	-24°
	Longitude -3,85°						
Sevilla	Latitude: 37,38°	-26,7°	-23,9°	-21,0°	-17,8°	0,7°	-30,8°
	Longitude -6,00°						
Valencia	Latitude: 39,45°	-20,1°	-17,0°	-13,9°	-10,5°	7,3°	-24,1°
	Longitude -0,38°						
Valladolid	Latitude: 41,63°	-22,5°	-19,9°	-17,1°	-14,2°	2,0°	-26,1°
	Longitude -4,72°						

Satellite		ASTRA/ Eutelsat W2 19,2°/16,0°	Eutelsat W2/Hotbird 16°/13°	Hotbird/ Eutelsat W2A 13°/10°	Eutelsat W2A/W3A 10°/7°	Atlantik Bird 3/2 -5,0°/-8,0°	ASTRA/ ASTRA 23,5°/19,2°
-----------	--	--------------------------------------	-----------------------------------	-------------------------------------	-------------------------------	-------------------------------------	--------------------------------

■ Spain (continued)

Vigo	Latitude: 42,20°	-25,2°	-22,8°	-20,4°	-17,7°	-2,4°	-28,7°
	Longitude -8,68°						
Zaragoza	Latitude: 41,65°	-19,2°	-16,3°	-13,4°	-10,3°	6,2°	-22,9°
	Longitude -0,88°						

■ Portugal

Beja	Latitude: 38,03°	-27,7°	-25,1°	-22,4°	-19,4°	-1,8°	-31,8°
	Longitude -7,88°						
Braganca	Latitude: 41,80°	-24,1°	-21,6°	-19,0°	-16,2°	-0,4°	-27,7°
	Longitude -6,83°						
Coimbra	Latitude: 40,25°	-26,5°	-24,0°	-21,4°	-18,6°	-2,3°	-30,2°
	Longitude -8,45°						
Faro	Latitude: 37,03°	-28,6°	-25,9°	-23,1°	-20,1°	-1,9°	-32,8°
	Longitude -7,92°						
Lissabon	Latitude: 38,70°	-28,2°	-25,7°	-23,1°	-20,3°	-3,3°	-32,2°
	Longitude -9,17°						
Porto	Latitude: 41,13°	-26,0°	-23,6°	-21,0°	-18,3°	-2,5°	-29,6°
	Longitude -8,67°						

■ Slovenia

Bled	Latitude: 46,40°	-3,3°	-0,4°	2,5°	5,3°	18,1°	-6,8°
	Longitude 14,10°						
Ljubljana	Latitude: 46,10°	-3,0°	0,0°	2,9°	5,7°	18,6°	-6,5°
	Longitude 14,50°						
Maribor	Latitude: 46,60°	-1,9°	1,0°	3,8°	6,6°	19,2°	-5,4°
	Longitude 15,60°						

■ Croatia

Dubrovnik	Latitude: 42,60°	0,5°	3,9°	7,1°	10,2°	23,6°	-3,5°
	Longitude 18,10°						
Koper	Latitude: 45,50°	-3,8°	-0,8°	2,1°	5,0°	18,4°	-7,4°
	Longitude 13,70°						
Osijek	Latitude: 45,50°	1,1°	4,1°	7,0°	9,8°	22,1°	-2,6°
	Longitude 18,70°						
Pula	Latitude: 44,80°	-3,8°	-0,7°	2,3°	5,3°	18,9°	-7,5°
	Longitude 13,80°						
Rijeka	Latitude: 14,40°	-3,1°	-0,1°	2,8°	5,8°	19,0°	-6,8°
	Longitude 13,80°						
Split	Latitude: 43,50°	-1,3°	2,0°	5,1°	8,2°	21,7°	-5,2°
	Longitude 16,40°						
Zadar	Latitude: 44,10°	-2,5°	0,7°	3,8°	6,8°	20,4°	-6,3°
	Longitude 15,20°						
Zagreb	Latitude: 45,80°	-1,5°	1,4°	4,3°	7,2°	19,9°	-5,1°
	Longitude 16,00°						

■ Serbia

Belgrad	Latitude: 44,80°	2,9°	6,0°	8,9°	11,7°	23,8°	-0,8°
	Longitude 20,50°						
Novisad	Latitude: 45,20°	2,2°	5,2°	8,1°	10,9°	23,1°	-1,5°
	Longitude 19,80°						

Satellite		ASTRA/ Eutelsat W2 19,2°/16,0°	Eutelsat W2/Hotbird 16°/13°	Hotbird/ Eutelsat W2A 13°/10°	Eutelsat W2A/W3A 10°/7°	Atlantik Bird 3/2 -5,0°/-8,0°	ASTRA/ ASTRA 23,5°/19,2°
■ Montenegro							
Podgorica	Latitude: 42,40°	1,8°	5,2°	8,4°	11,5°	24,7°	-2,2°
	Longitude: 19,30°						
■ Macedonia							
Skopje	Latitude: 42,00°	4,4°	7,7°	10,9°	13,9°	26,6°	-0,3°
	Longitude: 21,60°						
■ Bosnia-Herzegovina							
Sarajevo	Latitude: 43,80°	0,8°	4,0°	7,1°	10,1°	23,0°	-3°
	Longitude: 18,40°						
■ Hungary							
Budapest	Latitude: 47,50°	1,4°	4,2°	6,8°	9,5°	21,1°	-2°
	Longitude: 19,10°						
Debrecen	Latitude: 47,50°	3,6°	6,4°	9,0°	11,6°	22,7°	+0,2°
	Longitude: 21,60°						
Pecs	Latitude: 46,10°	0,6°	3,5°	6,4°	9,1°	21,4°	-3°
	Longitude: 18,20°						
Győr	Latitude: 47,70°	0,0°	2,8°	5,5°	8,1°	19,9°	-3,4°
	Longitude: 17,60°						
Szeged	Latitude: 46,20°	2,4°	5,3°	8,1°	10,8°	22,6°	-1,2°
	Longitude: 20,10°						
Szekesfehevar	Latitude: 47,10°	0,7°	3,6°	6,3°	9,0°	20,8°	-2,7°
	Longitude: 18,40°						
■ Czech Republic							
Brno	Latitude: 49,10°	-0,9°	1,8°	4,4°	6,9°	18,4°	-4,1°
	Longitude: 16,60°						
Budweis	Latitude: 49,00°	-2,7°	0,0°	2,6°	5,1°	17,0°	-5,9°
	Longitude: 14,50°						
Cheb	Latitude: 50,10°	-4,3°	-1,7°	0,7°	3,2°	14,9°	-7,4°
	Longitude: 12,40°						
Karlsbad	Latitude: 50,20°	-3,9°	-1,3°	1,2°	3,6°	15,2°	-6,9°
	Longitude: 12,90°						
Ostrau	Latitude: 49,80°	0,6°	3,2°	5,7°	8,1°	19,1°	-2,6°
	Longitude: 18,30°						
Pilsen	Latitude: 49,80°	-3,5°	-0,9°	1,6°	4,1°	15,8°	-6,6°
	Longitude: 13,40°						
Prag	Latitude: 50,10°	-2,7°	-0,1°	2,4°	4,9°	16,3°	-5,7°
	Longitude: 14,40°						
■ Slovakia							
Pressburg	Latitude: 48,20°	-0,5°	2,2°	4,9°	7,5°	19,2°	-3,8°
	Longitude: 17,00°						
Kosice	Latitude: 48,70°	3,2°	5,9°	8,4°	10,9°	21,7°	0°
	Longitude: 21,30°						

Multi-feed Application 6° Orbital Spacing

Satellite		ASTRA/Eutelsat W2 23,5°/16,0°	ASTRA/Hotbird 19,2°/13°	Eutelsat W2/ Eutelsat W2A 16°/10°	Hotbird/Eutelsat W3A 13°/7°
■ Germany					
Bad Reichenhall	Latitude: 47,72°	-6,1°	-2,9°	-0,1°	2,6°
	Longitude 12,90°				
Berlin	Latitude: 52,50°	-4,8°	-2,0°	0,3°	2,6°
	Longitude 13,42°				
Bremen	Latitude: 53,07°	-8,0°	-5,4°	-3,1°	-0,9°
	Longitude 8,83°				
Cottbus	Latitude: 51,75°	-4,2°	-1,4°	1,0°	3,4°
	Longitude 14,33°				
Dortmund	Latitude: 51,50°	-9,5°	-6,7°	-4,3°	-2,0°
	Longitude 7,47°				
Dresden	Latitude: 51,05°	-4,8°	-1,9°	0,6°	3,0°
	Longitude 13,73°				
Emden	Latitude: 53,35°	-9,1°	-6,5°	-4,3°	-2,1°
	Longitude 7,20°				
Erfurt	Latitude: 50,97°	-6,9°	-4,1°	-1,6°	0,8°
	Longitude 11,03°				
Flensburg	Latitude: 54,78°	-7,1°	-4,6°	-2,5°	-0,4°
	Longitude 9,45°				
Frankfurt/Main	Latitude: 50,12°	-9,0°	-6,1°	-3,6°	-1,1°
	Longitude 8,68°				
Freiburg/Brsg.	Latitude: 48,00°	-10,4°	-7,3°	-4,6°	-1,9°
	Longitude 7,83°				
Greifswald	Latitude: 54,08°	-4,6°	-2,0°	0,3°	2,4°
	Longitude 13,38°				
Hamburg	Latitude: 53,55°	-7,1°	-4,5°	-2,2°	0,0°
	Longitude 9,98°				
Hannover	Latitude: 52,37°	-7,5°	-4,8°	-2,5°	-0,2°
	Longitude 9,77°				
Kassel	Latitude: 51,30°	-8,1°	-5,3°	-2,8°	-0,5°
	Longitude 9,43°				
Kiel	Latitude: 54,32°	-6,8°	-4,2°	-2,0°	0,1°
	Longitude 10,13°				
Koblenz	Latitude: 50,33°	-9,9°	-7,0°	-4,5°	-2,1°
	Longitude 7,50°				
Leipzig	Latitude: 51,30°	-5,8°	-3,0°	-0,5°	1,9°
	Longitude 12,37°				
Magdeburg	Latitude: 52,12°	-6,2°	-3,4°	-1,1°	1,3°
	Longitude 11,63°				
Mönchengladbach	Latitude: 51,18°	-10,4°	-7,6°	-5,2°	-2,8°
	Longitude 6,45°				
München	Latitude: 48,13°	-7,2°	-4,0°	-1,3°	1,4°
	Longitude 11,57°				
Neubrandenburg	Latitude: 53,55°	-4,7°	-2,1°	0,2°	2,4°
	Longitude 13,25°				
Nürnberg	Latitude: 49,45°	-7,3°	-4,3°	-1,7°	0,9°
	Longitude 11,05°				
Osnabrück	Latitude: 52,28°	-8,8°	-6,1°	-3,8°	-1,5°
	Longitude 8,05°				

Satellite		ASTRA/Eutelsat W2 23,5°/16,0°	ASTRA/Hotbird 19,2°/13°	Eutelsat W2/ Eutelsat W2A 16°/10°	Hotbird/Eutelsat W3A 13°/7°
■ Germany (continued)					
Passau	Latitude: 48,57°	-5,5°	-2,3°	0,4°	3,0°
	Longitude 13,47°				
Pirmasens	Latitude: 49,20°	-10,2°	-7,2°	-4,6°	-2,1°
	Longitude 7,60°				
Plauen	Latitude: 50,50°	-6,2°	-3,2°	-0,7°	1,7°
	Longitude 12,13°				
Ravensburg	Latitude: 47,77°	-9,0°	-5,8°	-3,1°	-0,4°
	Longitude 9,60°				
Regensburg	Latitude: 49,02°	-6,5°	-3,4°	-0,8°	1,8°
	Longitude 12,10°				
Rostock	Latitude: 54,08°	-5,4°	-2,8°	-0,6°	1,5°
	Longitude 12,13°				
Stuttgart	Latitude: 48,80°	-9,0°	-6,0°	-3,3°	-0,7°
	Longitude 9,18°				
Trier	Latitude: 49,75°	-10,8°	-7,9°	-5,3°	-2,8°
	Longitude 6,63°				
Ulm	Latitude: 48,38°	-8,5°	-5,4°	-2,7°	0,0°
	Longitude 9,97°				
■ Austria					
Bregenz	Latitude: 47,50°	-9,0°	-5,7°	-3,0°	-0,2°
	Longitude 9,75°				
Graz	Latitude: 47,07°	-4,0°	-0,6°	2,3°	5,0°
	Longitude 15,45°				
Innsbruck	Latitude: 47,27°	-7,6°	-4,3°	-1,5°	1,3°
	Longitude 11,38°				
Klagenfurt	Latitude: 46,63°	-5,1°	-1,7°	1,2°	4,0°
	Longitude 14,33°				
Lienz	Latitude: 46,83°	-6,4°	-3,1°	-0,2°	2,6°
	Longitude 12,77°				
Linz	Latitude: 48,30°	-4,8°	-1,6°	1,1°	3,8°
	Longitude 14,30°				
Salzburg	Latitude: 47,80°	-6,0°	-2,8°	0,0°	2,7°
	Longitude 13,03°				
Wien	Latitude: 48,20°	-3,0°	0,2°	3,0°	5,6°
	Longitude 16,37°				
■ Switzerland					
Bern	Latitude: 46,95°	-11,1°	-7,9°	-5,1°	-2,3°
	Longitude 7,47°				
Genf	Latitude: 46,20°	-12,5°	-9,3°	-6,5°	-3,7°
	Longitude 6,15°				
Locarno	Latitude: 46,17°	-10,2°	-6,9°	-4,0°	-1,2°
	Longitude 8,78°				
Zürich	Latitude: 47,37°	-10,0°	-6,9°	-4,1°	-1,3°
	Longitude 8,53°				

Satellite		ASTRA/Eutelsat W2 23,5°/16,0°	ASTRA/Hotbird 19,2°/13°	Eutelsat W2/ Eutelsat W2A 16°/10°	Hotbird/Eutelsat W3A 13°/7°
■ Benelux countries					
Brügge (B)	Latitude: 51,22°	-12,7°	-10,0°	-7,7°	-5,4°
	Longitude 3,22°				
Brüssel (B)	Latitude: 50,85°	-12,0°	-9,3°	-6,9°	-4,5°
	Longitude 4,35°				
Den Haag (NL)	Latitude: 52,12°	-11,6°	-9,0°	-6,7°	-4,4°
	Longitude 4,28°				
Eindhoven (NL)	Latitude: 51,43°	-11,0°	-8,3°	-5,9°	-3,6°
	Longitude 5,47°				
Enschede (NL)	Latitude: 52,22°	-9,7°	-7,0°	-4,7°	-2,4°
	Longitude 6,88°				
Groningen (NL)	Latitude: 53,25°	-9,6°	-7,0°	-4,7°	-2,5°
	Longitude 6,58°				
Luxemburg (L)	Latitude: 49,62°	-11,2°	-8,3°	-5,7°	-3,2°
	Longitude 6,15°				
Maastricht (NL)	Latitude: 50,83°	-11,1°	-8,3°	-5,9°	-3,5°
	Longitude 5,67°				
■ France					
Bastia	Latitude: 42,67°	-10,8°	-7,0°	-3,8°	-0,5°
	Longitude 9,50°				
Bayonne	Latitude: 43,50°	-20,4°	-17,3°	-14,5°	-11,7°
	Longitude -1,47°				
Bordeaux	Latitude: 44,83°	-18,9°	-15,9°	-13,1°	-10,4°
	Longitude -0,60°				
Brest	Latitude: 48,40°	-19,6°	-17,0°	-14,7°	-12,4°
	Longitude -4,52°				
Calais	Latitude: 50,95°	-13,7°	-11,1°	-8,8°	-6,4°
	Longitude 1,93°				
Clermont-Ferrand	Latitude: 45,77°	-15,4°	-12,2°	-9,4°	-6,6°
	Longitude 3,07°				
Dijon	Latitude: 47,33°	-13,0°	-9,9°	-7,2°	-4,5°
	Longitude 5,05°				
Le Havre	Latitude: 49,50°	-15,8°	-13,1°	-10,7°	-8,3°
	Longitude 0,08°				
Limoges	Latitude: 45,83°	-16,8°	-13,8°	-11,1°	-8,3°
	Longitude 1,25°				
Lyon	Latitude: 45,77°	-13,9°	-10,7°	-7,8°	-5,0°
	Longitude 4,83°				
Marseille	Latitude: 43,30°	-14,5°	-11,0°	-7,9°	-4,8°
	Longitude 5,38°				
Metz	Latitude: 49,13°	-11,3°	-8,4°	-5,8°	-3,3°
	Longitude 6,17°				
Nantes	Latitude: 47,20°	-18,2°	-15,4°	-12,9°	-10,4°
	Longitude -1,55°				

Satellite		ASTRA/Eutelsat W2 23,5°/16,0°	ASTRA/Hotbird 19,2°/13°	Eutelsat W2/ Eutelsat W2A 16°/10°	Hotbird/Eutelsat W3A 13°/7°
-----------	--	----------------------------------	----------------------------	---	--------------------------------

■ France (continued)

Nizza	Latitude: 43,70°	-12,6°	-9,1°	-6,0°	-2,9°
	Longitude 7,23°				
Orleans	Latitude: 47,90°	-15,3°	-12,4°	-9,8°	-7,2°
	Longitude 1,87°				
Paris	Latitude: 48,83	-14,5°	-11,6°	-9,1°	-6,6°
	Longitude 2,33				
Reims	Latitude: 49,25°	-13,0°	-10,1°	-7,6°	-5,1°
	Longitude 4,02°				
Rennes	Latitude: 48,12°	-17,8°	-15,1°	-12,6°	-10,2°
	Longitude -1,68°				
Toulouse	Latitude: 43,62°	-17,9°	-14,6°	-11,7°	-8,8°
	Longitude 1,45°				
Tours	Latitude: 47,37°	-16,5°	-13,6°	-11,0°	-8,4°
	Longitude 0,67°				

■ Unigted Kingdom of Great Britain and Northern Ireland

Aberdeen	Latitude: 57,15°	-13,3°	-11,3°	-9,4°	-7,6°
	Longitude -2,10°				
Belfast	Latitude: 54,58°	-16,8°	-14,7°	-12,8°	-10,9°
	Longitude -5,93°				
Birmingham	Latitude: 52,50°	-15,6°	-13,2°	-11,0°	-8,9°
	Longitude -1,92°				
Bristol	Latitude: 51,43°	-16,6°	-14,1°	-11,9°	-9,7°
	Longitude -2,58°				
Glasgow	Latitude: 55,87°	-15,1°	-13,1°	-11,2°	-9,4°
	Longitude -4,23°				
London	Latitude: 51,50°	-14,9°	-12,3°	-10,1°	-7,8°
	Longitude -0,08°				
Manchester	Latitude: 53,50°	-15,2°	-12,9°	-10,9°	-8,8°
	Longitude -2,25°				
Newcastle	Latitude: 54,22°	-17,0°	-14,9°	-13,0°	-11,0°
	Longitude -5,90°				
Norwich	Latitude: 52,63°	-13,4°	-10,9°	-8,7°	-6,5°
	Longitude 1,28°				
Plymouth	Latitude: 50,38°	-18,2°	-15,7°	-13,5°	-11,3°
	Longitude -4,15°				

■ Italy

Ancona	Latitude: 43,62°	-6,5°	-2,7°	0,5°	3,6°
	Longitude 13,50°				
Bari	Latitude: 41,10°	-3,3°	0,9°	4,4°	7,7°
	Longitude 16,87°				
Bologna	Latitude: 44,50°	-8,4°	-4,8°	-1,7°	1,3°
	Longitude 11,33°				
Bozen	Latitude: 46,50°	-7,8°	-4,5°	-1,6°	1,3°
	Longitude 11,33°				

Satellite		ASTRA/Eutelsat W2 23,5°/16,0°	ASTRA/Hotbird 19,2°/13°	Eutelsat W2/ Eutelsat W2A 16°/10°	Hotbird/Eutelsat W3A 13°/7°
-----------	--	-------------------------------------	----------------------------	---	--------------------------------

■ Italy (continued)

Cagliari	Latitude: 39,25°	-12,6°	-8,4°	-4,7°	-1,1°
	Longitude 9,10°				
Catania	Latitude: 37,52°	-6,0°	-1,3°	2,7°	6,5°
	Longitude 15,07°				
Cosenza	Latitude: 39,28°	-4,3°	0,2°	3,9°	7,5°
	Longitude 16,23°				
Florenz	Latitude: 43,78°	-8,7°	-5,0°	-1,8°	1,3°
	Longitude 11,25°				
Foggia	Latitude: 41,47°	-4,7°	-0,7°	2,8°	6,2°
	Longitude 15,52°				
Genua	Latitude: 44,40°	-10,7°	-7,2°	-4,1°	-1,1°
	Longitude 8,93°				
Mailand	Latitude: 45,47°	-10,1°	-6,7°	-3,7°	-0,8°
	Longitude 9,17°				
Neapel	Latitude: 40,83°	-6,2°	-2,1°	1,5°	4,9°
	Longitude 14,28°				
Palermo	Latitude: 38,13°	-8,0°	-3,5°	0,4°	4,2°
	Longitude 13,33°				
Pescara	Latitude: 42,47°	-6,0°	-2,0°	1,3°	4,6°
	Longitude 14,22°				
Rimini	Latitude: 44,05°	-7,3°	-3,6°	-0,5°	2,6°
	Longitude 12,55°				
Rom	Latitude: 41,90°	-7,9°	-4,0°	-0,6°	2,8°
	Longitude 12,50°				
Sassari	Latitude: 40,73°	-12,6°	-8,6°	-5,1°	-1,7°
	Longitude 8,55°				
Taranto	Latitude: 40,50°	-3,0°	1,3°	4,8°	8,3°
	Longitude 17,18°				
Turin	Latitude: 45,07°	-11,7°	-8,2°	-5,3°	-2,3°
	Longitude 7,67°				
Trieste	Latitude: 45,65°	-5,8°	-2,3°	0,7°	3,6°
	Longitude 13,75°				
Venedig	Latitude: 45,45°	-7,2°	-3,7°	-0,7°	2,3°
	Longitude 12,33°				
Verona	Latitude: 45,45°	-8,4°	-5,0°	-2,0°	1,0°
	Longitude 11,00°				

■ Spain

Albacete	Latitude: 39,00°	-23,7°	-20,4°	-17,2°	-14,0°
	Longitude -1,83°				
Algeciras	Latitude: 36,15°	-29,1°	-25,9°	-22,8°	-19,6°
	Longitude -5,47°				
Alicante	Latitude: 38,38°	-23,0°	-19,4°	-0,7°	-12,8°
	Longitude -0,50°				

Satellite		ASTRA/Eutelsat W2 23,5°/16,0°	ASTRA/Hotbird 19,2°/13°	Eutelsat W2/ Eutelsat W2A 16°/10°	Hotbird/Eutelsat W3A 13°/7°
■ Spain (continued)					
Almeria	Latitude: 36,87°	-25,9°	-22,4°	-19,2°	-15,8°
	Longitude -2,45°				
Avila	Latitude: 40,65°	-25,0°	-21,9°	-19,1°	-16,2°
	Longitude -4,72°				
Badajoz	Latitude: 38,83°	-28,1°	-25,2°	-22,4°	-19,5°
	Longitude -6,98°				
Barcelona	Latitude: 41,35°	-18,6°	-15,1°	-11,9°	-8,7°
	Longitude 2,17°				
Burgos	Latitude: 42,35°	-22,9°	-19,9°	-17,2°	-14,3°
	Longitude -3,68°				
Cadiz	Latitude: 36,50°	-29,5°	-26,4°	-23,4°	-20,4°
	Longitude -6,33°				
Cartagena	Latitude: 37,63°	-24,0°	-20,4°	-17,1°	-13,7°
	Longitude -0,98°				
Cordoba	Latitude: 37,83°	-27,2°	-24,0°	-21,0°	-17,9°
	Longitude -4,83°				
Gijon	Latitude: 43,53°	-23,7°	-20,9°	-18,3°	-15,6°
	Longitude -5,70°				
Granada	Latitude: 37,17°	-26,6°	-23,3°	-20,2°	-16,9°
	Longitude -3,58°				
Ibiza	Latitude: 38,90°	-20,8°	-17,1°	-13,8°	-10,4°
	Longitude 1,43°				
La Coruna	Latitude: 43,33°	-25,7°	-23,1°	-20,7°	-18,2°
	Longitude -8,42°				
Madrid	Latitude: 40,42°	-24,4°	-21,2°	-18,3°	-15,4°
	Longitude -3,75°				
Malaga	Latitude: 36,72°	-27,7°	-24,4°	-21,3°	-18,1°
	Longitude -4,38°				
Palma de Mallorca	Latitude: 39,58°	-19,2°	-15,5°	-12,1°	-8,7°
	Longitude 2,65°				
Salamanca	Latitude: 40,97°	-25,5°	-22,5°	-19,8°	-17,0°
	Longitude -5,65				
San Sebastian	Latitude: 43,28°	-21,0°	-17,9°	-15,1°	-12,3°
	Longitude -1,97°				
Santa Cruz del Retamar	Latitude: 41,33°	-24,1°	-21,1°	-18,3°	-15,4°
	Longitude -4,23°				
Santander	Latitude: 43,45°	-22,3°	-19,4°	-16,7°	-14,0°
	Longitude -3,85°				
Sevilla	Latitude: 37,38°	-28,5°	-25,4°	22,5°	-19,4°
	Longitude -6,00°				
Valencia	Latitude: 39,45°	-22,1°	-18,7°	-15,5°	-12,2°
	Longitude -0,38°				
Valladolid	Latitude: 41,63°	-24,3°	-21,3°	-18,5°	-15,7°
	Longitude -4,72°				

Satellite		ASTRA/Eutelsat W2 23,5°/16,0°	ASTRA/Hotbird 19,2°/13°	Eutelsat W2/ Eutelsat W2A 16°/10°	Hotbird/Eutelsat W3A 13°/7°
■ Spain (continued)					
Vigo	Latitude: 42,20°	-26,7°	-24,1°	-21,6°	-19,1°
	Longitude -8,68°				
Zaragoza	Latitude: 41,65°	-21,1°	-17,8°	-14,9°	-11,8°
	Longitude -0,88°				
■ Portugal					
Beja	Latitude: 38,03°	-29,4°	-26,5°	-23,8°	-20,9°
	Longitude -7,88°				
Braganca	Latitude: 41,80°	-25,7°	-22,9°	-20,3°	-17,6°
	Longitude -6,83°				
Coimbra	Latitude: 40,25°	-28,1°	-25,3°	-22,7°	-20,1°
	Longitude -8,45°				
Faro	Latitude: 37,03°	-30,3°	-27,3°	-24,6°	-21,7°
	Longitude -7,92°				
Lissabon	Latitude: 38,70°	-29,8°	-27,1°	-24,5°	-21,7°
	Longitude -9,17°				
Porto	Latitude: 41,13°	-27,6°	-24,8°	-22,3°	-19,7°
	Longitude -8,67°				
■ Slovenia					
Bled	Latitude: 46,40°	-5,3°	-1,9°	1,0°	3,9°
	Longitude 14,10°				
Ljubljana	Latitude: 46,10°	-5,0°	-1,5°	1,4°	4,3°
	Longitude 14,50°				
Maribor	Latitude: 46,60°	-3,9°	-0,5°	2,4°	5,2°
	Longitude 15,60°				
■ Croatia					
Dubrovnik	Latitude: 42,60°	-1,8°	2,2°	5,5°	8,6°
	Longitude 18,10°				
Koper	Latitude: 45,50°	-5,9°	-2,3°	0,7°	3,6°
	Longitude 13,70°				
Osijek	Latitude: 45,50°	-1,0°	2,5°	5,5°	8,4°
	Longitude 18,70°				
Pula	Latitude: 44,80°	-5,9°	-2,3°	0,8°	3,8°
	Longitude 13,80°				
Rijeka	Latitude: 45,30°	-5,2°	-1,7°	1,4°	4,3°
	Longitude 14,40°				
Split	Latitude: 43,50°	-3,5°	0,3°	3,6°	6,6°
	Longitude 16,40°				
Zadar	Latitude: 44,10°	-4,6°	-0,9°	2,3°	5,3°
	Longitude 15,20°				
Zagreb	Latitude: 45,80°	-3,6°	-0,1°	2,9°	5,8°
	Longitude 16,00°				
■ Serbia					
Belgrad	Latitude: 44,80°	0,8°	4,4°	7,4°	10,3°
	Longitude 20,50°				
Novisad	Latitude: 45,20°	0,0°	3,6°	6,6°	9,5°
	Longitude 19,80°				

Satellite		ASTRA/Eutelsat W2 23,5°/16,0°	ASTRA/Hotbird 19,2°/13°	Eutelsat W2/ Eutelsat W2A 16°/10°	Hotbird/Eutelsat W3A 13°/7°
■ Montenegro					
Podgorica	Latitude: 42,40°	-0,5°	3,5°	6,8°	9,9°
	Longitude 19,30°				
■ Macedonia					
Skopje	Latitude: 42,00°	2,0°	6,0°	9,3°	12,4°
	Longitude 21,60°				
■ Bosnia-Herzegovina					
Sarajevo	Latitude: 43,80°	-1,4°	2,4°	5,6°	8,6°
	Longitude 18,40°				
■ Hungary					
Budapest	Latitude: 47,50°	-0,6°	2,7°	5,5°	8,2°
	Longitude 19,10°				
Debrecen	Latitude: 47,50°	1,7°	5,0°	7,7°	10,3°
	Longitude 21,60°				
Pecs	Latitude: 46,10°	-1,5°	2,0°	4,9°	7,7°
	Longitude 18,20°				
Győr	Latitude: 47,70°	-1,9°	1,4°	4,1°	6,8°
	Longitude 17,60°				
Szeged	Latitude: 46,20°	0,3°	3,8°	6,7°	9,4°
	Longitude 20,10°				
Szekesfehevar	Latitude: 47,10°	-1,2°	2,1°	5,0°	7,7°
	Longitude 18,40°				
■ Czech Republic					
Brno	Latitude: 49,10°	-2,7°	0,4°	3,1°	5,6°
	Longitude 16,60°				
Budweis	Latitude: 49,00°	-4,5°	-1,4°	1,3°	3,9°
	Longitude 14,50°				
Cheb	Latitude: 50,10°	-6,1°	-3,1°	-0,5°	2,0°
	Longitude 12,40°				
Karlsbad	Latitude: 50,20°	-5,6°	-2,6°	-0,1°	2,4°
	Longitude 12,90°				
Ostrau	Latitude: 49,80°	-1,2°	1,8°	4,4°	6,9°
	Longitude 18,30°				
Pilzen	Latitude: 49,80°	-5,3°	-2,3°	0,3°	2,8°
	Longitude 13,40°				
Prag	Latitude: 50,10°	-4,4°	-1,4°	1,2°	3,6°
	Longitude 14,40°				
■ Slovakia					
Pressburg	Latitude: 48,20°	-2,4°	0,8°	3,5°	6,2°
	Longitude 17,00°				
Kosice	Latitude: 48,70°	1,4°	4,5°	7,2°	9,7°
	Longitude 21,30°				