

Universal Wideband feed system 10,70-12,75 GHz

About this Guide

This document is part of the product.

- ▶ Read these instructions for use before the initial use of the antenna set.
- ▶ Perform all operating steps described in the manuals in the specified sequence.

For the most up-to-date version of this document, go to www.kathrein-ds.com.



Keep these instructions for future reference. Pass them on to any new owners when selling or transferring the unit.



Features

- Universal Wideband feed system with 2 outputs
- Suitable for Kathrein offset parabolic antennas, type CAS.. (60, 80, 90, 120 cm Ø)
- For reception of satellites in the Ku band, such as ASTRA, EUTELSAT and TürkSat
- 50% less cable material required: To receive one satellite, only two cables from the LNB to the wideband multiswitch are required, with Multifeed, two satellites can be received with just four cables
- Energy saving - only max. 1,2 W power consumption
- The feed system complies with ASTRA specifications for universal Wideband feed systems
- Power supply via coax cable
- Multifeed-suitable due to compact design
- Full protection of LNB and cable connections in a ventilated housing, protection category IP 54

Scope of Delivery

- UAS 582
- 2 x self install F-type plug
- Instructions for use

Transport and Storage

- ▶ Transport and store the device in its original packaging.
- ▶ Make sure there is no water condensation build-up.

Intended Use

- ▶ The device described is designed solely for the installation of satellite receiver systems and may only be installed by trained specialist personnel.
- ▶ The UAS 582 feed system may only be mounted to the listed Kathrein parabolic antennas.
- ▶ If it is used in any other way or if the provisions of this document are disregarded, the guarantee and warranty will become void.
- ▶ The manufacturer is not liable for accidents caused by the user on the opened device.
- ▶ Unauthorized opening and repair attempts lead to the loss of the warranty claim.

Safety Instructions



The UAS 582 feed system may only be mounted to the listed Kathrein parabolic antennas. The feed system is subject to the same safety and danger warnings as listed in the instructions for using of fset parabolic antennas. Please follow these instructions at all times, as otherwise you or other people may be exposed to danger (electric shock through overhead lines, risk of falling down, falling parts, thunderstorm etc.).

Mounting and Connection of the feed system

Fixing the feed system (Fig. 1)

1. Position the feed system as desired on the multifeed plate at the end of the bracket (see antenna instructions)
2. Fasten the feed system on the front part using the Allen wrench (torque: 4.5 Nm).



All fastening and tightening can be effected with a Allen wrench (SW4).

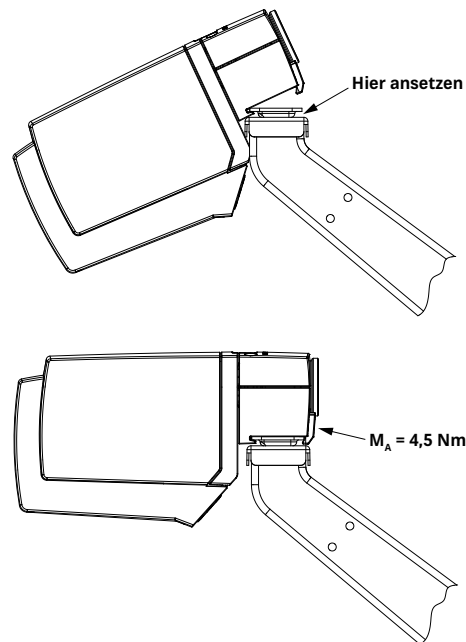

Fig. 1: Fixing the feed system

Setting the polarisation (Fig. 2)

See the value in the table Tab. 1, S. 5 for the polarisation setting.

If the value differs from the pre-set 0°, proceed as follows:

1. Loosen both Allen screws (S).
2. Turn the feed system to set the reference mark to the value given in the polarisation pre-setting table.
3. Tighten the Allen screws (S) evenly, alternating between both.
Torque: max. 4.5 Nm

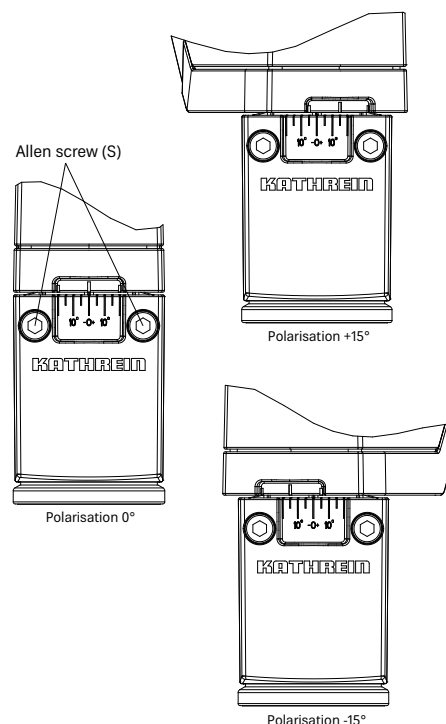

Fig. 2: Setting the polarisation

Cable connection

1. Loosen the Allen screws (S) at the rear end of the cover until the cover can be unlocked by applying light downward pressure ①; remove cover ②.



If the feed system is not only exchanged but a new antenna system is being installed, proceed first as described in the section "Aligning the satellite reception system" and then return to "Cable connection".

2. Mount the supplied F-type plug onto the Kathrein cable types LCD 90, LCD 111A+ or LCD 115A+ and connect to the LNB (see Fig. 4).
First screw the nuts of the F connectors onto the LNB and then tighten them with a tool to the end stop (M_A 3.4 Nm). We recommend using the ZAW 16 tool (BN: 21410012) to strip the coaxial cable.
3. When connecting the matrix and the LNB, make sure the correct output is assigned (mark cables if necessary).
4. It is important to ensure that the bending radius of the corresponding cable is not undershot.
5. Lead the connected cable forwards and insert sideways into the cable fastening (see close-up in Fig. 5 below).
6. Slide on the cover until it fits into the groove and locks in the bottom section. Tighten Allen screw (S).

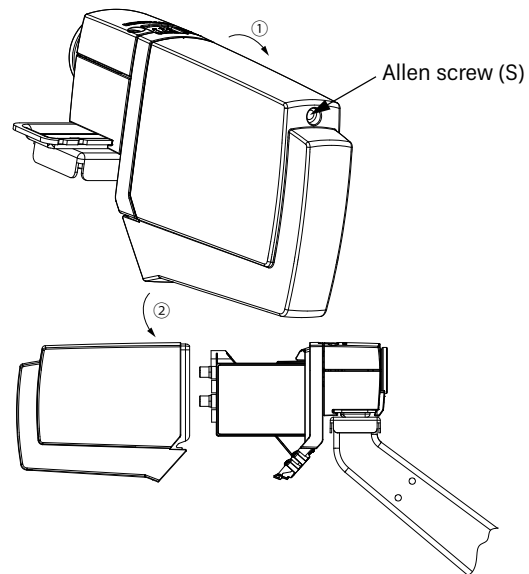

Fig. 3: Remove cover

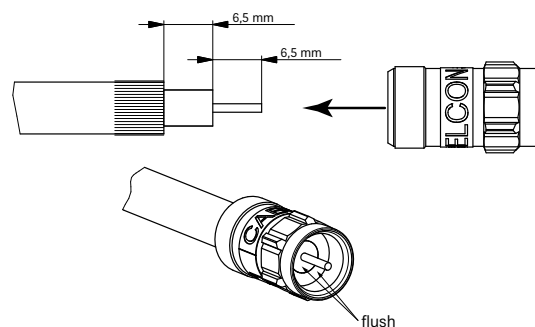

Fig. 4: Plug mounting

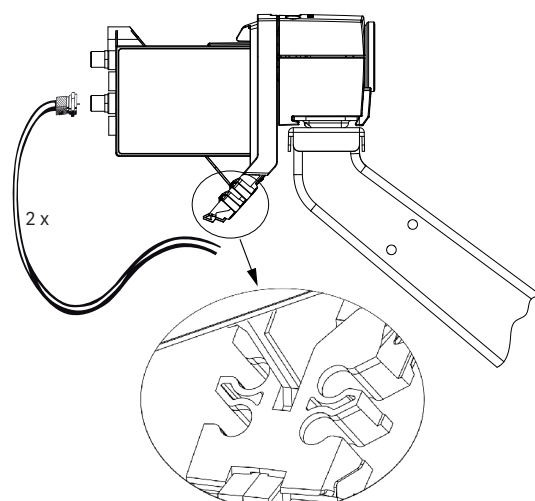

Fig. 5: Cable connection

Ausrichten der Satelliten-Empfangsanlage (Fig. 6)



If the feed system is only to be exchanged, the antenna does not have to be aligned.

1. Perform basic adjustment according to the azimuth/elevation table available at https://www.kathrein-ds.com/download/azimut-elevations-tabelle_de/?tmstv=1753247204.
2. Search for satellites by rotating the azimuth axis (see https://www.kathrein-ds.com/download/azimut-elevations-tabelle_de/?tmstv=1753247204) and set to maximum display (when using a Kathrein MSK satellite measuring receiver ...). If no measuring receiver is available, set to the best signal strength/quality (see Fig. 7 and „Level optimisation“).
3. Adjust elevation until max. signal level or best signal strength/quality are obtained.
4. Check azimuth adjustment and correct if necessary. Firmly fix all bolts to advised torque moment M_A (see mounting instructions for parabolic antenna).
5. Continue as described in section “Cable connection”.

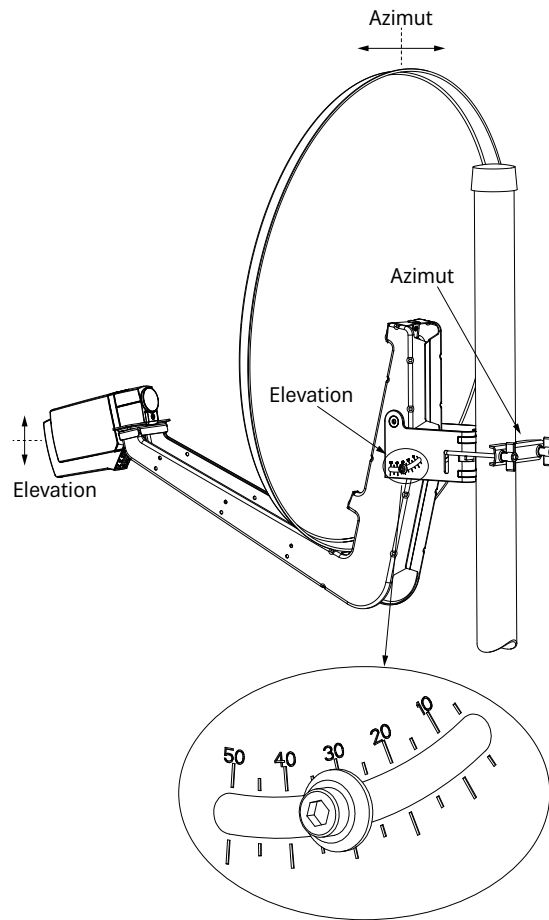

Fig. 6: Align the antenna

Level optimization

As the antenna lobe (Fig. 7) in the maximum range is only slightly curved, an excellent signal strength/quality can be expected when it is aligned to this range. However, it may also be that the antenna at the left or right is “only just” aligned to this excellent reception range. As soon as the antenna stanchion experiences any vibration the supposed excellent signal strength/quality can drop off at the steep edge of the lobe. To avoid this, the reception position should be set to the middle of the maximum level.

Proceed as follows when conducting the setting-up process using a Kathrein test receiver (MSK...):

1. Mark the centre of the mast clamp.
2. Turn the antenna to the left until the level drops by, e. g. 8 dB. Transfer the mast clamp marking to the mast.
3. Turn antenna to the right until the level drops by 8 dB. Transfer the mast clamp marking to the mast.
4. Position the mast clamp marking in the exact centre of the mast markings. This will ensure that an ideal reception situation is given.
5. Proceed in a similar manner to optimise the elevation.

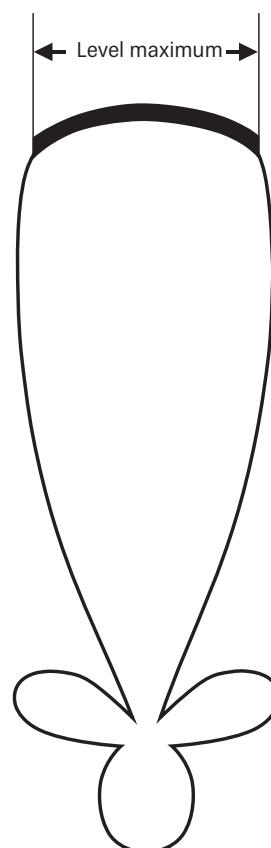

Fig. 7: Antenna lobe

Pre-setting the polarisation for compact feed systems in various countries

Polarisation-presettings for compact feed systems in various European countries (the geographical centre of each country is the point of reference in each case). In case of polarisation-presettings exceeding $\pm 25^\circ$, the feed system is to be set to the respective stop.

Country	Satellites												
	TÜRKSAT 42° Ost	ASTRA 28.2° Ost	ASTRA 23.5° Ost	ASTRA 19.2° Ost	EUTELSAT 16A 16° Ost	EUTELSAT HOTBIRD 13B / 13C / 13D 13° Ost	EUTELSAT 10A 10° Ost	EUTELSAT 7A / 7B 7° Ost	THOR 5/6 0.8° West	EUTELSAT 5 West A 5° West	EUTELSAT 8 West A / D 8° West	HISPASAT 1D / 1E 30° West	
Albanien	-23	-2	3	8	5	8	11	15	22	26	28	41	
Belgien	-27	-11	-8	-5	-9	-7	-5	-2	4	8	10	25	
Bulgarien	-17	4	10	14	10	13	16	19	25	29	31	41	
Dänemark	-19	-4	-1	2	-3	-1	1	3	8	11	13	24	
Deutschland	-23	-7	-4	0	-4	-2	0	3	9	12	14	28	
Frankreich	-32	-16	-11	-9	-13	-10	-7	-5	3	7	10	27	
Finnland	-7	6	8	10	5	6	7	9	12	14	15	21	
Griechenland	-21	2	6	14	11	14	18	21	28	32	34	46	
Großbritannien	-26	-13	-10	-8	-13	-11	-9	-7	-2	1	3	17	
Italien	-29	-10	-4	-1	-4	-1	3	6	15	19	22	37	
Irland	-30	-17	-14	-12	-17	-15	-13	-11	-6	-3	0	15	
Kroatien	-24	-5	0	4	1	4	7	10	17	20	23	36	
Liechtenstein	-26	-10	-5	-2	-6	-3	0	2	10	13	16	31	
Luxemburg	-26	-11	-7	-4	-8	-6	-3	-1	6	9	12	26	
Monaco	-31	-13	-9	-5	-9	-6	-3	0	9	13	16	32	
Niederlande	-25	-10	-6	-4	-8	-6	-4	-1	5	8	10	24	
Norwegen	-11	2	4	6	1	2	4	5	9	10	12	19	
Österreich	-24	-6	-1	2	-2	0	3	6	13	16	18	32	
Polen	-17	0	4	7	2	5	7	9	15	18	20	31	
Portugal	-43	-28	-24	-22	-26	-23	-20	-17	-8	-3	0	24	
Rumänien	-16	4	10	13	9	11	14	17	23	26	28	38	
Schweden	-12	1	3	6	1	2	4	5	9	11	13	21	
Schweiz	-28	-11	-6	-3	-7	-5	-2	1	8	12	15	30	
Serbien-Montenegro	-21	-1	5	9	5	8	11	14	21	24	26	39	
Slowakei	-18	0	4	7	3	6	8	11	17	20	22	34	
Slowenien	-24	-5	-1	3	-1	2	5	8	15	18	21	34	
Spanien	-40	-24	-21	-17	-21	-18	-15	-11	-2	3	6	29	
Tschechien	-21	-4	0	4	0	2	5	7	13	16	19	31	
Ungarn	-20	-1	3	7	3	6	9	11	18	21	23	35	

Tab. 1: Pre-setting the polarisation for compact feed systems in various countries

Application examples

UAS 582 with Single-Cable Multi-Switch EXD 1524

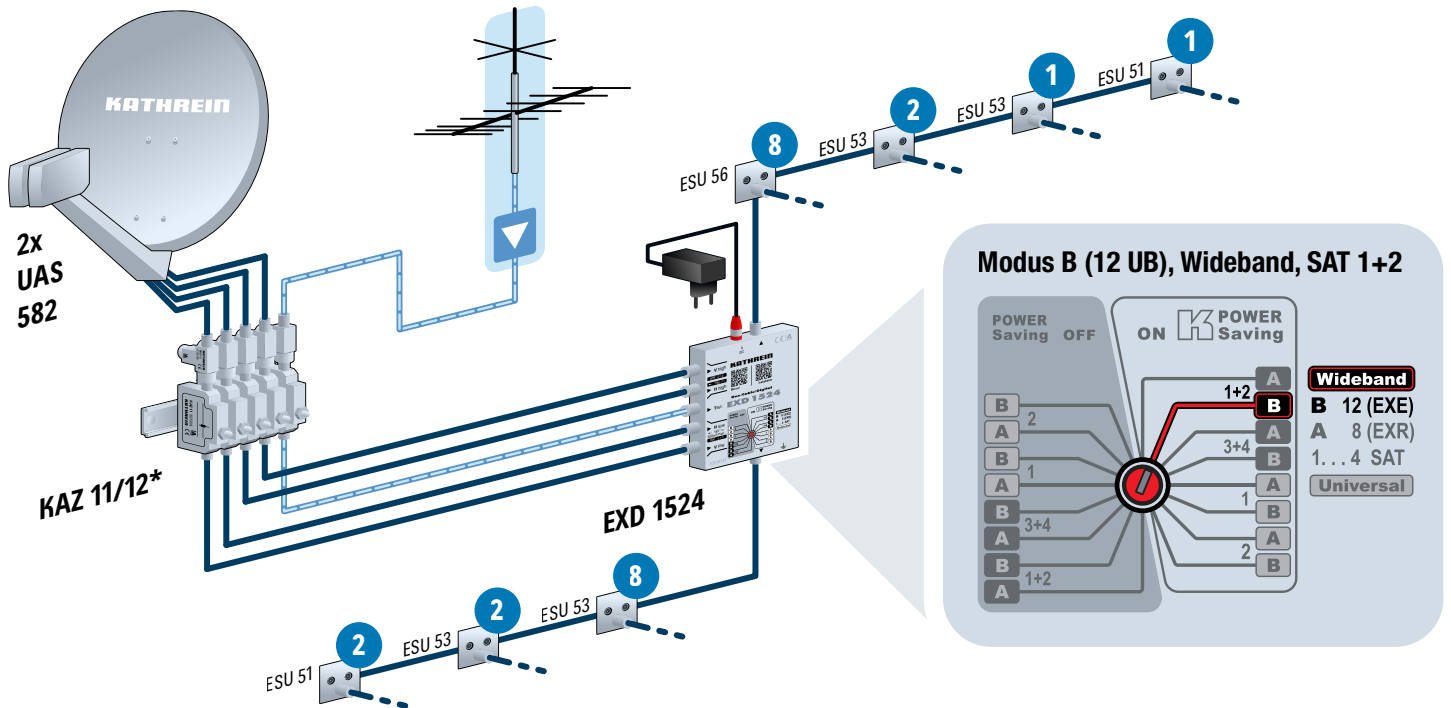

UAS 582 with Single-Cable Multi-Switch EXD 1532

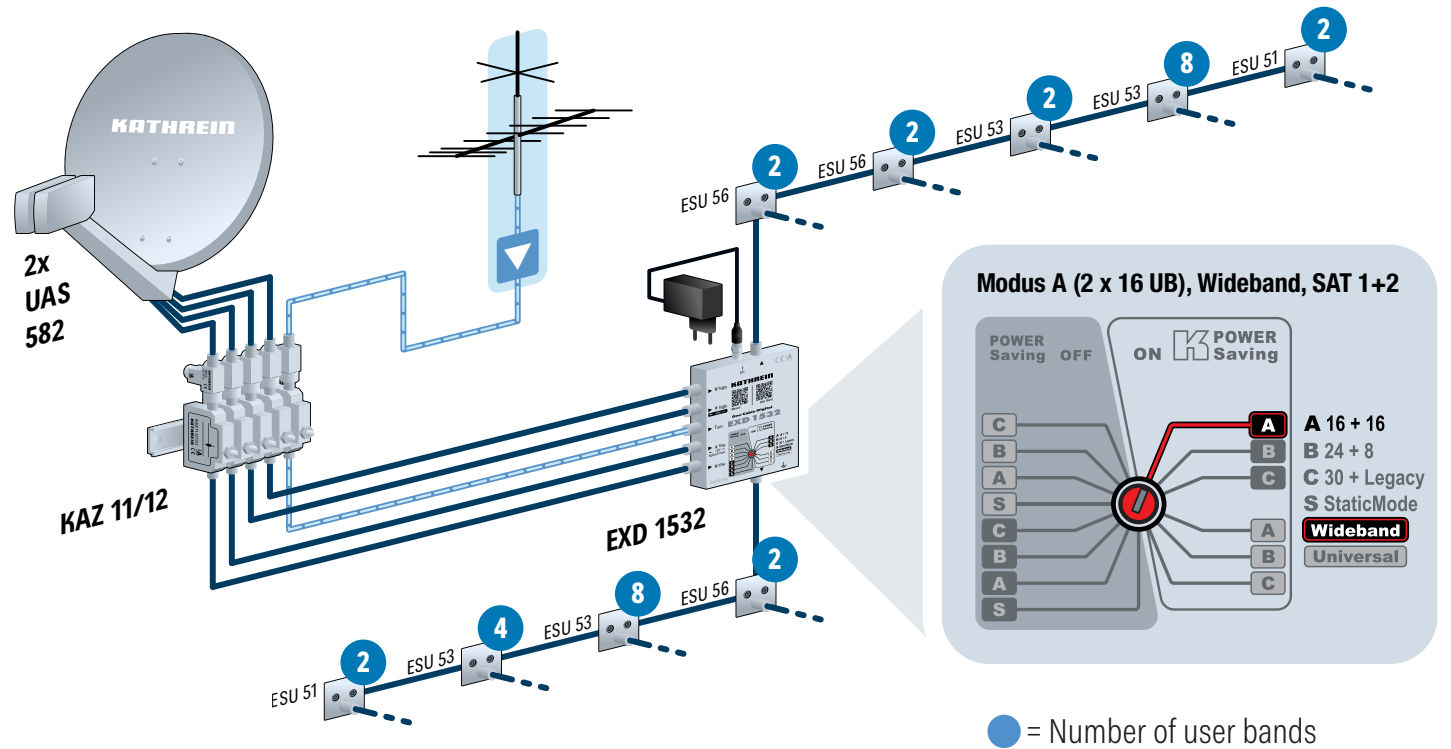

Technical data

Type Order no.		UAS 582 20110032
Suitable for parabolic antennas		CAS 60, CAS 80, CAS 90, CAS 120
Polarisation		1 x vertikal und 1 x horizontal
Input frequency	GHz	10,70-12,75
Gain	dB	> 50
Output frequency	MHz	300-2350
Oscillator frequency (L.O.)	GHz	10,40
Phase noise (L.O.: 10,60 GHz)	dBc	1 kHz: -50-10 kHz: -75-100 kHz: -95
System figure of merit (G/T)	dB/K	Siehe Offset-Parabolantennen
Polarisation decoupling	dB	min. 22
Output/impedance	Ω	2 x F-Connector/75
Supply voltage LNB	V	9 ... 19
Power consumption LNB	W	max. 1,2
Dimensions	mm	235 x 135 x 44
Packing dimensions	mm	295 x 185 x 65
Approx. weight	kg	0,8

Service and Support



All relevant information (address, telephone number, e-mail address, opening hours) for repairs or help with problems with our products can be found at:

<https://www.kathrein-ds.com/en/support/service-points>

Please note that there are different contact persons for **repair** and **support**!

You can find a contact form here: <https://www.kathrein-ds.com/en/contact>



Warranty Conditions

- The warranty only covers replacement of the product.
- The LNB must be installed by qualified personnel in compliance with the enclosed instructions.
- Do not modify the LNB, e.g. by drilling.
- Do not cause any mechanical damage to the LNB, e.g. deformations caused by falling from a roof.
- Do not cause any chemical damage to the LNB, e.g. due to exposure to solvents, lacquers, detergents or the like.
- Furthermore, the warranty does not apply to damage caused by force majeure, e. g. lightning, storm or hail.
- Only the original invoice is acceptable for warranty claims.
- The consumer can make use of the warranty rights free of charge.

Disposal



Electronic equipment

Electronic equipment is not domestic waste – in accordance with directive 2012/19/EC OF THE EUROPEAN PARLIAMENT AND THE COUNCIL dated 04th July 2012 concerning used electrical and electronic appliances, it must be disposed of properly. At the end of its service life, take this unit for disposal at a designated public collection point.